



The Registrar
Punyashlok Ahilyadevi Holkar Solapur
University, Solapur – 413 255

E-Tender Notice No. PAHSUS/Engg/2024/ 216 for the year 2024-2025
TENDER DOCUMENT

For the work of : Supply, installation, testing and commissioning of MRL (Machine Room less) five Nos. 15 (fifteen) passenger and One No. 10 (ten) passenger lifts including minor civil work at administrative building and Examination Bhavan at Punyashlok Ahilyadevi Holkar Solapur University, Solapur.

Approximate Estimated Cost

Put to Tender :- **Rs. 97,00,000/-**

Security Deposit for Contract :- **5% of tendered cost**

Earnest Money for Tender :- **Rs. 97,000/-**

Accepted Tender :- **Rs. _____**

Cost of Blank Tender Form :- **Rs. 2500/- + GST@18% = Rs. 2950/-**

Time Limit :- **4 calendar months (including monsoon)for 15 passengers**
3 calendar months (including monsoon)for 10 passengers

Date of downloading tender document: **08.08.2024 to 22.08.2024**

Dates of asking clarifications : **Between 12.08.2024 and 26.08.2024**

Date of uploading clarification : **31.08.2024**

Date of uploading financial bid :- **02.09.2024 from 11.00 a.m. to 07.09.2024 upto 17.00 p.m.**

Consulting Architects : **DESIGN GROUP (INDIA)**
Architects, Engineers, Planners, Project Management Consultants, Int. Designers
11/12/13, R.N.A. Arcade, Lokhandwala Complex, Andheri West, Mumbai – 400 053.
Tel. : 022-26316203 / 26321083 / 26302293.
Email : designgroupindia@gmail.com

**PUNYASHLOK AHILYADEVI HOLKAR
SOLAPUR UNIVERSITY, SOLAPUR**

**E-TENDER NOTICE NO. PAHSUS/Engg/2024/ 216 FOR
YEAR 2024-2025**

Sealed on line e-tenders in C-1 form are invited by the Registrar of Punyashlok Ahilyadevi Holkar Solapur University, from the reputed leading lift manufacturing agencies with separately quoting yearly maintenance (AMC) by the Registrar, P.A.H. Solapur University, Solapur.

NAME OF THE WORK	ESTIMATE COST (Rs.)	EARNEST MONEY (Rs.)	COMPLETION PERIOD	COST OF TENDER (Rs.)
1. Supply, installation, testing and commissioning of five Nos. MRL (Machine room less) of 15 (fifteen) passenger lifts including minor civil work at Administrative building and examination bhavan at Punyashlok Ahilyadevi Holkar Solapur University, Solapur	16,50,000 x 5 Nos. = 82,50,000/- +	Total 97,000/-	4 Months (four months) including Monsoon for five lifts	2,500.00 + 18% GST = Rs.2950/-
2. Supply, installation, testing and commissioning of One No. MRL (Machine room less) of 10 (fifteen) passenger lifts including minor civil work at Administrative building and examination bhavan at Punyashlok Ahilyadevi Holkar Solapur University, Solapur	14,50,000 x 1 No. = 14,50,000/- Total cost (82,50,000/- + 14,50,000/- = 97,00,000/-)		3 Months (Three months) including monsoon for one No. 10 passenger lift	

The blank tender forms are available on E-tendering module on Government of Maharashtra: <https://mahatenders.gov.in> from 08.08.2024 to 22.08.2024.

The tenderers can download the entire tender documents from web site.

The last date of submission of E-tender documents duly filled in shall be received from 02.09.2024 to 07.09.2024 upto 17.00 pm and envelope No.1 will be opened on the 11.09.2024.

The period of asking clarification shall be 12.08.2024 to 26.08.2024 and the clarifications shall be uploaded on 31.08.2024 at 5.00 p.m.

For further details please see detailed tender notice on <https://mahatenders.gov.in> , <https://su.digitaluniversity.ac> web sites. Conditional tenders will not be accepted.

The Registrar, Punyashlok Ahilyadevi Holkar Solapur University, Solapur reserves the right to accept or reject the lowest or any other tender or all tenders without assigning any reason whatsoever.

REGISTRAR

PUNYASHLOK AHILYADEVI HOLKAR SOLAPUR UNIVERSITY

PUNYASHLOK AHILYADEVI HOLKAR SOLAPUR UNIVERSITY, SOLAPUR
TENDER NOTICE No. : PAHSUS / Engg / 2024 / 216 FOR YEAR 2024

Name of work : Supply, installation, testing and commissioning of Five Nos. MRL (Machine room less) of 15 passenger lifts and one No.10 passenger MRL lift including minor civil work at Administrative Building and Examination Bhavan of Punyashlok Ahilyadevi Holkar Solapur University, Solapur.

TENDER SCHEDULE

Assume date of Publication of Tender Notice as on _____

Sr. No	PUNYASHLOK AHILYADEVI HOLKAR SOLAPUR UNIVERSITY STAGE	VENDOR STAGE	START DATE & TIME	EXPIRY DATE & TIME
1.	Main tender release	-	Thursday 08.08.2024	Thursday 22.08.2024
2.	-	Main tender document downloading	Thursday 08.08.2024	Thursday 22.08.2024
3.		Ask clarification	Monday 12.08.2024	Monday 26.08.2024
4.	Uploading clarification (On making report on clarification)	-	-	Saturday 31.08.2024
5.		Price-bid uploading along with complete tender document with clarification duly signed with tender cost of Rs. 2500/- + 18% GST = Rs.2950/- and EMD of Rs. 97,000.00 through online payment	Monday 02.09.2024	Friday 07.09.2024
6.		Envelope No. 1 opening (Technical)	Monday 09.09.2024	
7.		Envelope No. 2 opening (financial bid) (Tender opening C1)		Thursday 12.09.2024

NOTES :

- 1 All eligible / interested tenderer are required to be enrolled on portal <https://mahatenders.gov.in> before downloading tender documents and participate in e-tendering.
- 2 Tenderer are requested to contact on following telephone number for any doubts / information / difficulty regarding online process. Tel. : 0217-2744771 / 72 / 73 / 74 / 76 Ext. No. 199 / 111 / 110 and Shri Rahul Swami : Mobile : 9209000369, Email : enggsec@sus.ac.in of Punyashlok Ahilyadevi Holkar Solapur University
- 3 The amount for Earnest Money Deposit and Tender cost should be deposited online only. Tenderers should submit the documents, related to tender, online.
Copy of required documents (submitted in Envelope No. 01) as per tender volume also should be submitted personally within two days of opening of tender i.e. by 12.09.2024 upto 17.00 p.m. in the office of the University Engineer, Punyashlok Ahilyadevi Holkar Solapur University, Solapur.
Earnest Money Exemption Certificate is not applicable / consider for the University Works.

Successful tenderer should submit original receipt to the Finance & Account Officer, Punyashlok Ahilyadevi Holkar Solapur University, Solapur that the amount of Earnest Money Deposit and Tender Cost is deposited by the contractor in the account of Finance & Account Officer, Punyashlok Ahilyadevi Holkar Solapur University, Solapur, Construction Department, Punyashlok Ahilyadevi Holkar Solapur University, Solapur.

- 4 Other instructions can be seen in the tender document. All or any one of the tender may be rejected by the University Authority without assigning any reason whatsoever.
5. Tender notice of this work can also be seen on Punyashlok Ahilyadevi Holkar Solapur University website <http://su.digitaluniversity.as>
6. The tenderer can ask clarification if any required between 12.08.2024 to 26.08.2024 and the clarification shall be uploaded on 31.08.2024 upto 17.00 p.m.
7. Right to reject any or all tenders without assigning reason therefore is reserved by Registrar of the Punyashlok Ahilyadevi Holkar Solapur University, Solapur.

REGISTRAR

PUNYASHLOK AHILYADEVI
HOLKAR SOLAPUR UNIVERSITY,
SOLAPUR

CONTRACTOR

No. of correction

REGISTRAR

PUNYASHLOK AHILYADEVI HOLKAR SOLAPUR UNIVERSITY, SOLAPUR
TENDER NOTICE No.PAHSUS/Engg/2024/ 216 FOR YEAR 2024-2025

Name of work : Supply, installation, testing and commissioning of five Nos. MRL(Machine Room Less) of 15 passenger lifts and one No. 10 passenger MRL lift including minor civil work at Administrative Building and Examination Bhavan of Punyashlok Ahilyadevi Holkar Solapur University, Solapur.
RECAPITULATION SHEET

SUMMARY OF COST

Sr. No.	Description	Approximate Estimated cost
1.	Lift cost	
1.1	15 passenger lift : Rs. 16,50,000/- x 5 Nos.	Rs. 82,50,000.00
1.2	10 passenger lift : Rs. 14,50,000/- x 1 No.	Rs. 14,50,000.00
1.3.	TOTAL COST OF LIFTS	Rs. 97,00,000.00
Rs. 97,00,000.00 (Rupees Ninety Seven Lacs only)		
2.	Reimbursement of GST @ 18.00% charges	Rs.
3.	Reimbursement of Insurance amount – 1% on awarded cost	Rs.
4.	Reimbursement of Royalty charges	Rs.
5.	Testing charges	Rs.

Note :

- The above estimated cost of Rs. 97,00,000.00 is approximate exclusive of reimbursable charges stated under Sr.No. 2, 3, 4 & further as described below.
- The amount of insurance as per SSR note section B (i) of section B shall be 0.5% of awarded cost Rs. _____ which shall be Rs. _____ and will be reimbursement only on documentary evidence of receipt of payment and insurance policy in original.
- The amount of royalty charges are as per the letter No. SOL / PWC / Prakalp-I Marathi / 2286 / 2021 dated 05 July 2021 shall be Rs. _____ - _____ and on which quoted cost shall not be admissible.
- GST as 18% of approximate estimated cost is taken in Recapitulation sheet as provision which will be payable only on receipt of documentary evidence of payment of GST and only such payment of GST will be reimbursed.

CONTRACTOR

No. of correction

REGISTRAR

PUNYASHLOK AHILYADEVI
HOLKAR SOLAPUR UNIVERSITY,
SOLAPUR

E-TENDER NOTICE No. PAHSUS/Engg/2024/ 216 FOR YEAR 2024-25

Online tenders (e-tender) in C-1 form are invited from the most reputed lift agencies having turnover above Thirty Crores without considering the cost of AMC for the following work by the Registrar, Punyashlok Ahilyadevi Holkar Solapur University, Solapur, phone No. 0217- 2744771/72/73/74/76 on Government of Maharashtra Electronic Tender Management system <https://mahatenders.gov.in> The AMC charges should be separately quoted in attached sheet. The AMC charges should be separately quoted in attached sheet.

The details can be viewed and downloaded only directly from the Government of Maharashtra e-tendering Portal <https://mahatenders.gov.in>. This detailed tender notice is available on Notice Board of the office of The Registrar, Punyashlok Ahilyadevi Holkar Solapur University, Solapur.

NOTE:

1. All eligible / interested contractors are mandated to get enrolled on e-tendering portal <https://mahatenders.gov.in>
2. To process the tenders online bidders are required to obtain digital certificate.
3. Contractors can contact 0217-2744771 / 72 / 73 / 74 / 76 Ext. 199 / 111/ 110 and Shri RahulSwami Mobile : 9209000369. Email : enggsec@sus.ac.in for clarification of their doubts regarding the process of Electronic Tendering System.
4. Submission of documents pertaining to tender form fee and EMD of tender can be uploaded.

REGISTRAR
PUNYASHLOK AHILYADEVI
HOLKAR SOLAPUR UNIVERSITY,
SOLAPUR

CONTRACTOR

No. of correction

REGISTRAR

PUNYASHLOK AHILYADEV
HOLKARSOLAPUR UNIVERSITY,
SOLAPUR

E-TENDER NOTICE No. PAHSUS / Engg./2024 / 216 FOR YEAR 2024-2025

DETAILS OF WORK

Name of work : Supply, installation, testing and commissioning of five Nos. MRL(Machine Room Less) of 15 passenger lifts including minor civil work at Administrative Building and Examination Bhavan of Punyashlok Ahilyadevi Holkar Solapur University, Solapur.
and
Supply, installation, testing and commissioning of one No. MRL(Machine Room Less) of 10 passenger lifts at Administrative Building and Examination Bhavan including minor civil work of Punyashlok Ahilyadevi Holkar Solapur University, Solapur.

Approximate Estimated cost
put to tender : Rs. 97,00,000.00In

words Rupees : Rupees Ninety Seven Lacs only

Earnest money deposit : Rs. 97,000.00

The Earnest Money should be deposited only through Net Banking by Linking <https://mahatenders.gov.in>. The proof / receipt and duly attested copies shall uploaded at the time of submission.

Total security deposit shall be 5% (FIVE) percent of agreed / allotted cost while 50% of total security deposit shall be paid as initial security deposit on acceptance of tender / on issue of letter of intent while balance 50% of security deposit shall be recovered at the rate of 5% from each running bill. The time of completion of all six lifts shall be four months including monsoon.

TO BE FILLED BY THE CONTRACTOR

I / We have quoted my / our offer in lump-sum amount in words as well as in figures. I / we further undertake to enter into contract in regular ' C-1 ' form in Punyashlok Ahilyadevi Holkar Solapur University, Solapur.

Name & Signature of Contractor /
Power of Attorney holder
with complete address

CONTRACTOR

No. of correction

REGISTRAR

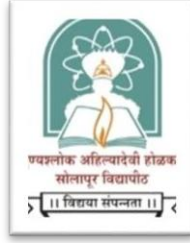

**THE REGISTRAR
PUNYASHLOK AHILYADEVI
HOLKAR**

SOLAPUR UNIVERSITY, SOLAPUR

Supply, installation, testing and commissioning of MRL (Mahine RoomLess)
five Nos. 15 (fifteen) passenger and One No. 10 (ten) passenger

NAME OF WORK : lifts including minor civil works at Administrative Building and
Examination Bhavan at Punyashlok Ahilyadevi Holkar Solapur
University, Solapur

Tender Notice No. : PAHSUS / Engg / 2024 / 216 for Year 2024-2025

e-TENDER DOCUMENTS

Volume I : General rules and directions for the guidance of contractors(Part I)

Part II : Conditions of contract, Additional conditions, specifications etc.

Part III : Special condition on Lift

Volume II : Letter of offer

1 TENDERING PROCEDURE

1.1. BLANK TENDER FORMS

Tender forms can be downloaded from the e-tendering Portal of Government of Maharashtra i.e. <https://mahatenders.gov.in> after entering the details of payment towards tender fees as per the tender schedule.

- 1.2. 1.2.1. Tender forms can be downloaded from the e-tendering portal of Government of Maharashtra i.e. <https://mahatenders.gov.in> after entering.
- 1.2.2. The tenderers have to make a payment of Rs. Nil online as service charges for the use of Electronic tendering during online Bid Data Decryption and Re-encryption Stage of the tender.
- 1.2.3. For any assistance on the use of Electronic tendering system, the users may call : Shri. Rahul Swami Mobile : 9209000369 or Tel. No. 0217-2744771 / 72 / 73 / 74 / 76 Ext. 199 / 111 / 110 email : enggsec@sus.ac.in of Punyashlok Ahilyadevi Holkar Solapur University, Solapur.
- 1.2.4. Tenderers should install the Mandatory Components available on the Home Page of <https://mahatenders.gov.in> under the section ' Mandatory Components ' and make the necessary Browser settings provided under section ' Internet Explore settings '.

1.3. GUIDELINES TO BIDDERS ON THE OPERATIONS OF ELECTRONIC TENDERING SYSTEM OF PUNYASHLOK AHILYADEVI HOLKAR SOLAPUR UNIVERSITY, SOLAPUR.

A. Pre-requisite to participate in the tenders processed by the University.

1. Enrolment and Empanelment of contractors on Electronic Tendering System

The contractors interested in participating in the tenders of University processed using the Electronic Tendering system shall be required to enroll on the Electronic Tendering system to obtain User ID.

After submission of application for enrolment on the system, the application information shall be verified by the Authorized Representative of the Service Provider. If the information is found to be complete, the enrolment submitted by the Vendor shall be approved.

The contractors may obtain the necessary information on the process of enrolment and empanelment may visit the information published under the link Enroll under the section E-tendering toolkit for Bidders on the Home Page of the Electronic Tendering system.

2. Obtaining a Digital Certificate :

The Bid Data that is prepared online is required to be encrypted and the hash value of the Bid Data is required to be signed electronically using a Digital Certificate (Appropriate class). This is required to maintain the security of the Bid Data and also to establish the identity of the Contractor transacting on the system.

CONTRACTOR

No.s of correction

REGISTRAR

The Digital certificates are issued by an approved certifying Authority authorized by the Controller of certifying Authorities of Government of India through their Authorized Representatives upon receipt of documents required to obtain a Digital Certificate.

Bid data / information for a particular tender may be submitted only using the Digital certificate which is used to encrypt the data / information and sign the hash value during the Bid Preparation and Hash Submission stage. In case during the process of preparing and submitting a Bid for a particular tender, the contractor loses his / her Digital signature Certificate (i.e. due to virus attack, hardware problem, operating system problem); he / she may not be able to submit the Bid online. Hence, the Users are advised to store his / her Digital Certificate securely and if possible, keep a backup at safe place under adequate security to be used in case of need.

In case of online tendering, if the Digital Certificate issued to an Authorized User of a Partnership firm is used for signing and submitting a bid, it will be considered equivalent to a No objection certificate / power of attorney to that User to submit the bid on behalf of the Partnership firm. The Partnership firm has to authorize a specific individual via an authorization Certificate signed by a partner of the firm (and in case the applicant is a partner, another partner in the same firm is required to authorize) to use the digital certificate as per Indian Information Technology Act, 2000.

Unless the Digital Certificate is revoked, it will be assumed to represent adequate authority of the Authority User to bid on behalf of the firm for the Tenders processed on the Electronic Tender Management System of Government of Maharashtra as per Indian Information Technology Act, 2000. The digital signature of this Authorized User will be binding on the firm. It shall be the responsibility of Partners of the firm to inform the certifying authority of Sub certifying authority, if the Authorized User changes, and apply for fresh Digital Signature Certificate. The procedure for application of a Digital Signature Certificate will remain the same for the new Authorized User.

The same procedure holds true for the Authorized Users in a Private / Public Limited Company. In this case, the Authorization Certificate will have to be signed by the Director of the company or the Reporting Authority of the Applicant.

For information on the process of application for obtaining Digital Certificate, the Contractors may visit any Certifying Authority.

3. Recommended Hardware and Internet Connectivity

To operate on the Electronic Tendering System, the Contractors are recommended to use Computer System with at least 1 GB of RAM and broadband connectivity with minimum 512 kbps bandwidth.

CONTRACTOR

No. of correction

REGISTRAR

4. Set up of Computer System for executing the operations on the Electronic Tendering System

To operate on the Electronic Tendering System of Government of Maharashtra, the Computer System of the Contractors is required to be set up. The contractors are required to install utilities available under the section Mandatory Installation components on the Home Page of the System.

The Utilities are available for download freely from the above mentioned section. The contractors are requested to refer to the E-tendering Toolkit for Bidders available online on the Home Page to understand the process of setting up the System.

5 Payment for Service Provider fees :

In addition to the Tender Document Fees payable to Punyashlok Ahilyadevi Holkar Solapur University, Solapur the contractors shall pay service providers fees of Rs. NIL through **online payments** gateway service available on electronic Tendering System. For the list of options for making online payments, the Contractors are advised to visit the link E-Payment Options under the section E-Tendering Toolkit for Bidders on the Home Page of the Electronic Tendering System.

B. Steps to be followed by contractors to participate in the e-Tenders processed by the University.

1. Preparation of online Briefcase

All Contractors enrolled on the Electronic Tendering System of Government of Maharashtra are provided with dedicated briefcase facility to store documents / files in digital format. The Contractors can use the **online briefcase** to store their scanned copies of frequently used documents / files to be submitted as a part of their bid response. The contractors are advised to store the relevant documents in the briefcase before starting the Bid Preparation and Hash submission stage.

In case, the Contractors have multiple documents under the same type (e.g. multiple Work Completion Certificates) as mentioned above, the Contractors are advised to either create a single pdf file of all the documents of same type or compress the documents in a single compressed file in zip or rar formats and upload the same.

It is mandatory to upload the documents using the briefcase facility. Therefore, the Contractors are advised to keep the documents ready in the briefcase to ensure timely bid preparation.

Note: Uploading of documents in the briefcase does not mean that the documents are available to Punyashlok Ahilyadevi Holkar Solapur University, Solapur at the time of Tender Opening stage unless the documents are specifically attached to the bid during the online Bid Preparation and Hash Submission stage as well as during Decryption and Re-encryption stage.

CONTRACTOR

No. of correction

REGISTRAR

2 Online viewing of Detailed Notice Inviting Tenders:

The Contractors can view the Detailed Tender Notice along with the Time Schedule(Key Dates) for all the Live Tenders released by **Punyashlok Ahilyadevi Holkar Solapur University** on the home page of Solapur University's Web site &

e-Tendering Portal on <https://mahatenders.gov.in> under the section OrganizationTenders.

3 Download of Tender Documents:

The Pre-qualification / Main Bidding Documents are available for free downloading. However to participate in the online tender, the bidder must purchase the bidding documents online by filling up details of the payment towards the cost of Tender FormFee.

4 Online Bid Preparation and Submission of Bid Hash (Seal) of Bids:

Submission of Bids will be preceded by online bid preparation and submission of the digitally signed Bid Hashes (Seals) within the Tender Time Schedule (Key Dates) published in the Detailed Notice Inviting Tender. The Bid Data is to be prepared in the templates provided by the university. The templates may be either form based, extensible tables and / or up loadable documents. In the form based type of templates and extensible table type of templates,the contractors are required to enter the data and encrypt the data using the Digital Certificate. In the upload able document type of templates, the Contractors are required to select the relevant document / compressed file (containingmultiple documents) already uploaded in the briefcase.

Notes :

- a. The Contractors upload a single document or a compressed file containing multiple documents against each unloading option.
- b. The Hashes are the thumbprint of electronic data and are based on one – way algorithm. The Hashes establish the unique identity of Bid Data.
- c. The bid hash values are digitally signed using valid Class – II or Class – III Digital Certificate issued by any Certifying Authority. The Contractors are required to obtain Digital Certificate inadvance.
- d. After the hash value of bid data is generated, the Contractors cannot make any change / addition in its bid data. The bidder may modify bids before the deadline for Bid Preparation and Hash Submission as per Time Schedule mentioned in the Tenderdocuments.
- e. This stage will be applicable during both, Pre-bid /Pre-qualification and Financial Bidding Processes.

5. Close for Bidding (Generation of Super Hash Values):

After the expiry of the cut-off time of Bid Preparation and Hash Submission stage to be completed by the Contractors has lapsed, the Tender will be closed by the Tender Authority.

The Tender Authority from Punyashlok Ahilyadevi Holkar Solapur University, Solapur generate and digitally sign the Super Hash values (Seals).

6 Decryption and Re-encryption of Bids (submitting the Bids online):

After the time for generation of Super Hash values by the Tender Authority from Punyashlok Ahilyadevi Holkar Solapur University, Solapur has lapsed, the Contractors have to make the online payment of **Rs. Ni I** towards the fees of the Service Provider.

After making online payment towards Fees of Service Provider, the Contractors are required to decrypt their bid data using their Digital Certificate and immediately re-encrypt their bid data using the Public Key of the Tendering Authority. The Public Key of the Tendering Authority is attached to the Tender during the Close for bidding stage.

Note: The details of the Processing Fees shall be verified and matched during the Technical Opening stage.

At this time, the Contractors are also required to upload the files for which they generated the Hash values during the Bid Preparation and Hash Submission stage.

The Bid Data and Documents of only those Contractors who have submitted their Bid Hashes (Seals) within the stipulated time (as per the Tender Time Schedule), will be available for decryption and re-encryption and to upload the relevant documents from Briefcase. A Contractor who has not submitted his Bid Preparation and Hash Submission stage within the stipulated time will not be allowed to decrypt / re-encrypt the Bid data / submit documents during the stage of Decryption and Re-encryption of Bids (submitting the Bids online).

7 Short listing of Contractors for Financial Bidding Process:

The Tendering Authority will first open the Technical Bid documents of all Contractors and after scrutinizing these documents will shortlist the Contractors who are eligible for Financial Bidding Process. The shortlisted Contractors will be intimated by email.

8 Opening of the Financial Bids:

The Contractors may remain present in the Office of the Tender Opening Authority at the time of opening of Financial Bids. However, the results of the Financial Bids of all Contractors shall be available on the e-Tendering Portal of Government of Maharashtra i.e. <https://mahatenders.gov.in> immediately after the completion of opening process.

9 Tender Schedule (Key Dates):

The Contractors are strictly advised to follow the Dates and Times allocated to each stage under the column "Contractor Stage" as indicated in the Time Schedule in the Detailed Tender Notice for the Tender. All the online activities are time tracked and the Electronic Tendering System enforces time-locks that ensure that no activity or transaction can take place outside the Start and End Dates and Time of the stage as defined in the Tender Schedule.

At the sole discretion of the Tender Authority, the time schedule of the Tender stages may be extended. Joint venture is not allowed.

2. EARNEST MONEY AND SECURITY DEPOSIT.

Scanned copy of Earnest Money Deposit (E.M.D.) which should be paid online and scan copy should be submitted as per tender schedule to the University Engineer.

2.1. Earnest money exemption certificate will not be accepted.

CONTRACTOR

Nos. of correction

REGISTRAR

- 2.2 The amount of earnest money will be forfeited, in case a successful contractor does not pay the amount of initial security deposit within the time specified as stipulated by the Registrar and complete the contract documents. In all other cases, earnest money will be refunded back to other contractors after deposition of Initial Security Deposit by successful contractor.

2.3 SECURITY DEPOSIT

The total Security Deposit to be paid shall be **5% (Five percent)** of agreed quoted amount.

The successful tenderer shall have to deposit half of the Security Deposit by cash or by Demand Draft in favour of **Finance & Account Officer,**

Punyashlok Ahilyadevi Holkar Solapur University, Solapur. Failing which his earnest money will be forfeited to the Registrar. The balance 50% security deposit will be recovered from running account bills at 5% of amount shown in item (d)

of the memorandum in printed C-1 form or as may be decided by the Registrar during course of execution of the work looking to the position and circumstances that may prevail, whose orders will be final and binding on the contractor.

The Security deposit for the due performance of the contract shall be as detailed in the tender documents elsewhere. Fifty percent of the Security deposit will have to be deposited within ten days of the acceptance of the tender and the remaining fifty percent will be recovered from the running bills as the rate as specified in the tender form on the cost of work as per CSR prevailing at the time of acceptance of tender.

Initial Security Deposit should be deposited by Demand Draft in favour of **Finance & Account Officer, Punyashlok Ahilyadevi Holkar Solapur University, Solapur.**

2.4. PERFORMANCE SECURITY DEPOSIT shall be (as per Government Resolution Public Works Department No.BDG2016/Pra.Kra-2/Bldg.2/dated 12/2/2016)

- 2.5. In the event of failure of the tenderer to pay initial security deposit within 10 days (unless extended in writing by the Registrar) from the date of receipt of notice of acceptance of his tender, the amount of earnest money shall be forfeited to University and the acceptance of his tender, shall be considered withdrawn. Except that in the event of the notice of acceptance of the tender not being issued within 120 days of the date of opening of **Envelope No.2 (financial bid)**. The tenderer shall have the option (to be intimated in writing in good time before the expiry of 120 days period) of withdrawing his tender, in which case the earnest money should be refunded in full. All the tenders shall remain open for acceptance for 120 days from the date fixed for opening of envelope No.2. (Financial bid) and thereafter until it is withdrawn by the tenderer by notice in writing as per condition No. 2 of the Memorandum.

- 2.6. Earnest money of the unsuccessful Tenderers will be refunded online after the work order issued to the successful tenderer or on the expiry of the validity period whichever is earlier automatically through e-Tender portal.

- 2.7 The acceptance of the tender may be intimated to the contractor telegraphically or otherwise and either by the officer competent to accept the tender or any authority in the department including Government and such intimation shall be deemed to be an intimation of acceptance of the tender given by the authority competent to accept the tender.

- 2.8 In case there is difference between amount written in figures and words, the **Lower offer** will be taken as **final**.

3. Income Tax

The Income Tax and surcharge thereon will be deducted from bill amount at the rates amended from time to time or as intimated by the competent Income Tax authority, whether measured bill, advance payment or secured advance.

4. Other Taxes

Labour welfare tax (Upkar) and any other statutory deduction as applicable and amended by the govt. from time to time will be deducted from each running bill of workdone of the contractor by the University. However, the GST shall be reimbursed to the contractor of submitting the documentary evidence of payment of GST to respective to the authority.

5. Insurance

As per the Govt. Resolution No. FD/Insurance-1098/Case No. 28/98, dated 19-08-1998 and Director of Insurance Maharashtra, Mumbai letter dated 26-04-2005 Contractor has to submit Govt. Insurance policy for the work.

6. Royalty Charges

The royalty charges shall be recovered from Contractor's bill.

7. Building and other construction workers cess

Building and other construction workers cess @ 1% or at the rate amended from time totime as intimated by the competent authority of building and other construction workers Welfare Dept. 1996 will be deducted from bill amount whether measured bill, advance payment or secured advance.

8. TENDERING PROCEDURE

8.1. The tender shall be unconditional, conditional tender shall be summarily rejected.

8.2. EXAMINATION OF DRAWING AND SITE CONDITIONS:

The tenderers shall in his own interest carefully examine the drawings, conditions of contract and specifications etc. He shall also inspect the site and acquaint himself aboutthe climate, physical and all weather conditions prevailing at site, the nature magnitude, special features, and practicability of the works. All existing and required means of communications and access to site, availability of housing and other facilities, the availability of labour and materials, labour camp site, stores, godown etc. He shall obtain all necessary information as to the risk, contingencies and other circumstances which may affect and influence the tender. No claims on any of the above or any other factors will be entertained by the Government. Should there be any discrepancy or doubt or obscurity to be observed by him, he shall set forth in writing such discrepancies, doubts, obscurity and submit the same to the **Registrar, Punyashlok Ahilyadevi Holkar Solapur University, Solapur** for elucidation as soon as possible.

9 TENDERING PROCEDURE

9.1. CLARIFICATION OF TENDER

The tenderers may ask the clarifications on tender w.e.f. 12.08.2024 to 26.08.2024 regarding the workand tender in writing and the clarifications will be given / uploaded on 31.08.2024 upto 5.00 p.m.

These clarifications duly signed by tenderer should be uploaded alongwith tender documents which willbe opened on 09.09.2024 with opening of Envelope No. 1 (Technical). These clarifications will form the part of conditions of contract

The tender submitted by tenderer shall be based on the clarification/additional facility issued (if any) by the Department and his tender shall be unconditional. Conditional tenders will be summarily rejected.

All tenderers are cautioned that the tenders containing any deviation from the contractual terms and conditions, specifications or other requirements, and conditional tenders will be rejected.

10 Manner of Submission of Tender and its Accompaniments:

10.1. ENVELOPE NO. 1 : (DOCUMENTS)

The first envelope “Envelope No.1” shall contain the following documents..

- I. **Scanned copy** of forwarding letter.
- II. **Scanned copy** of EMD and Tender Cost amount shall be deposited online, (TrueCopy thereof duly Self attested) to be submitted as per the tender Schedule.
- III. **Scanned copy** of Certificate in Original or an attested copy thereof duly Self Attested showing the works of lifts of such magnitude are done in last five years.
- IV. **Scanned copy** of Details of other lift works tendered for and in hand with the value of work unfinished on the last date of submission of tender (In the proforma of **Statement No. I**. The Statement from the Heads of the Offices under whom the works are in progress should be enclosed of Lift contractor.
- V. **Scanned copy** of the List of owned Machinery immediately available with the tenderer for use on this work and list of machinery proposed to be utilized on this work, but not immediately available and the manner in which it is proposed. (In the proforma of **Statement No. II**)
- VI. **Scanned copy** of details of one single work of similar type completed of such magnitude by the contractor during last three years i.e. **2021-2022, 2022-23, 2023-24** (In the proforma of **Statement No. III**)
- VII. **Scanned copy** of details of Technical personnel on the rolls of the tenderers. (In the proforma of **Statement No. IV**)
- VIII. **Scanned copy** of partnership deed and Power of Attorney, in case of a Firm, tendering for work. (True copy duly Self Attested).
- IX. **Scanned copy** of Valid Professional Tax Registration Certificate in the form of PTR and PTE under section (1) of section 5 of Maharashtra State Tax on Profession, Trade callings and Employment Act 1975, Rule 3 (2) for employees including technical personnel from the Professional Tax office of the concerned District of Maharashtra with its latest valid clearance certificate. “*No dues Clearance certificate*” from competent authority should be submitted.
- X. **Scanned copy** of Valid GST registration certificate from Maharashtra State Sale Tax Department.

10.2. ENVELOPE NO. 2: TENDER: (Financial Bid)

Refer to Section Schedule of online tendering procedure at Sr. No. 1.3.

10.3. SUBMISSION OF TENDER:

Refer to Section ‘**Guidelines to Bidders on the operations of Tendering System of Punyashlok Ahilyadevi Holkar Solapur University, Solapur**’ for details.

10.4. OPENING OF TENDERS:

On the date specified in the Tender Schedule, following procedure will be adopted for opening of the tender:

CONTRACTOR

No. of correction

REGISTRAR

10.4.1. ENVELOPE NO.1: (Documents)

First of all **Envelope No. 1** of the tender will be opened **online** to verify its contents as per requirements. If the various documents contained in this envelope do not meet the requirements of the Department, a note will be recorded accordingly by the tender opening authority and the said tenderer's **Envelope No.2 (Financial Bid)** will not be considered for further action, but the same will be recorded. The decision of the Tender opening authority in this regard will be final and binding on the contractor.

10.4.2. ENVELOPE NO .2 : (FINANCIAL BID)

This Envelope shall be open **online** if contents of Envelope No. 1 are found to be acceptable to the Department and / or fulfill the Qualifying Criteria. The tendered rates, quoted shall sealed and intimated to contractor through e-mail.

10.5. TIME LIMIT :

The work is to be completed within time limit as specified in the N.I.T which shall be reckoned from the date of written order of commencing the work and shall be inclusive of monsoon period.

10.6. TENDER RATE :

No alteration in the form of tender and the schedule of tender and no addition in the scope of special stipulation will be permitted. Rates quoted for the tender shall be taken as applicable to all leads and lifts.

10.7. TENDER UNITS :

The tenderers should particularly note that the unit mentioned in the Schedule "B" on which the rates are based. No change in the units shall be allowed. In the case of difference between the rates written in figures and in words the correct rate will be one, which is lower of the two.

10.8. TENDER ACCEPTANCE:

Acceptance of tender will rest with the **University Buildings & Works Committee, Punyashlok Ahilyadevi Holkar Solapur University, Solapur** who reserve the right to reject any or all tenders without assigning any reasons therefore. The tenderer whose tender is accepted will have to enter into a regular C -1 agreement within 10 days of being notified to do so. In case failure on the part of Tenderer to sign the agreement within the stipulated time, the earnest money paid by him shall stand forfeited and the offer of the tenderer shall be considered as withdrawn by him.

10.9. POWER OF ATTORNEY:

If the tenderers are a firm or company, they should in their forwarding letter mentioning the names of all the partners together with the name of person who holds the power of attorney authorizing him to conduct all transactions on behalf of the body, along with the tender.

10.10. The tenderer may in the forwarding letter mention any points he may wish to make clear but right is reserved to reject the same or the whole of the tenders if the same become conditional tender thereby.

10.11. The contractor or the firms tendering for the work shall inform the Department if they appoint their authorized Agent on the work.

CONTRACTOR

No. of correction

REGISTRAR

10.12. Any dues arising out of contract will be recovered from the contractor as arrears of land revenue if not paid amicably, moreover, recovery of Government dues from the contractors will be effected from the payment due to the contractor from any other Government works under execution with them.

10.13. All pages of tender documents, specifications corrections slips etc. shall be initialed by the tenderer. The tenderer should bear full signature of the tenderer or his authorized power of attorney holder in the case of firm.

10.14. VALIDITY PERIOD:

The offer shall remain open for acceptance for minimum period of **120 days** from the date of opening of Envelope No.2 (financial bid) and thereafter until it is withdrawn by the contractor by notice in writing duly addressed to the authority. (Refer to memorandum of C-1 form chapter).

- 11 The contractor will have to sign the original copy of the tender papers and the drawings According to which the work is to be carried out. The contractor shall also have to give a declaration to the effect that, he has fully studied the plans, specifications, local conditions and availability of labour and materials and that he has quoted his rates with the consideration to all these factors.
- 12 The right is reserved to revise or amend the contract documents prior to the date notified for the receipt of tenders or extended date. Such deviations, amendments or extensions, if any, shall be communicated in the form of corrigendum by letter or / and by notice in News Papers as may be considered suitable.
- 13 The tender submitted by the tenderer remain valid for a period of **120 days** from the date of opening of envelope No.2 (financial bid). Tenderer also see para 2 of General Rules etc. of contract form.
- 14 The contractor(s) whose tender is accepted is required to note that no foreign exchange will be released by the university.
- 15 The tenderers, which do not fulfill all or any of the conditions or are incomplete in any respect are liable to summary rejection.
- 16** Right to reject any or all tenders without assigning reason there for is reserved. The acceptance of the tender lies with the **University Buildings & Works Committee, Punyashlok Ahilyadevi Holkar Solapur University, Solapur.**
- 17 The e-tender Notice shall form part of the tender agreement.

CONTRACTOR

No. of correction

REGISTRAR

18 Instruction to Contractor:

- 1** In case the tenderer whose offer is found lowest is requested to negotiate and reduce the offer, if the contractor does not respond within a period of 10 days the tender accepting authority without issuing any reminder reserves the right to reject such tender.
- 2** In case the contractor, who is informed of acceptance of his tender, does not remit the initial Security Deposit within a period of 10 days, the tender accepting authority reserves the right to forfeit the Earnest Money Deposit without issuing any reminder to take further action according to the tender provision.
- 3** As per Government instruction it is proposed to make payment of Contractor's bill through ECS/NEFT system. For this purpose contractor should open his Bank Account in a Bank having Core-Banking facility only.
- 4** Contractor shall submit a certificate to the effect that "All the payments to the Labour /Staff are made in Bank Accounts of Staff linked to Unique Identification Number (AADHAR CARD)." The certificate shall be submitted by the Contractor within 60 days from the commencement of contract. If the time period of Contract is less than 60 days then such certificates shall be submitted within 15 days from the date of commencement of contract [Govt. Resolution No.Tender-2016/ Pr.Kr.20/Shikana/ Ema-2, Dated 9/12/2016]
- 5** Govt. Resolution No. Bhakas 2019 / Pra.Kra.83 /Udyog4 dated 13 September 2019of Energy and employee department of Maharashtra state.

CONTRACTOR

No. of correction

REGISTRAR

STATEMENT -1**STATEMENT OF LIST OF WORKS OF LIFT IN HAND AND WORKS TENDERED FOR
ASON LAST DATE OF SUBMISSION OF THIS TENDER****NAME OF CONTRACTOR:****(i) WORKS INHAND**

Sr. No.	Name of work	Agreement No.	Tendered Amount	Date of commencement	Stipulated date of completion.	Value of work already done.	Value of Balance work to be executed in next 18 months	Probable date of completion.	Remarks
1	2	3	4	5	6	7	8	9	10
SAMPLE FORM									

(ii) WORKS TENDERED FOR

Sr. No.	Name of Work	Name and Address of client	Tendered Amount	Time limit	Probable date when decision is expected	Other relevant details, if any.
	2	3	4	5	6	7
SAMPLE FORM						

Note:

1. This is only a standard form. Details are to be furnished in this format in the form of typewritten statement which shall be scanned enclosed in envelope No. 1 duly signed.
2. The documentary proof of work in hand / works tendered for should be submitted also be scanned with this statement duly attested by Gazette Officer.

SIGNATURE OF CONTRACTOR

CONTRACTOR

No. of correction

REGISTRAR

STATEMENT - II**STATEMENT SHOWING THE DETAILS OF PLANT AND MACHINERY****IMMEDIATELY AVAILABLE WITH TENDERER FOR THIS WORK****NAME OF CONTRACTOR:**

Sr. No.	Name of Equipment	No. of Units	Kind and make	Capacity	Age and Condition.	Present Location	Remarks
	2	3	4	5	6	7	8
SAMPLE FORM							

Note: Use separate sheet for Civil and Electrical Works.**Note: 1.** This is only a standard form. Details are to be furnished in this format in the form of type written statements which shall be scanned enclosed in envelope No. 1 duly signed**2.** The documentary proof of having own machinery should also be scanned and submitted with this statement duly attested by Gazetted Officer.**STATEMENT - III****STATEMENT SHOWING THE DETAILS OF SIMILAR TYPE AND MAGNITUDE CARRIED****OUTBY THE CONTRACTOR DURING LAST THREE YEARS****NAME OF CONTRACTOR:**

Sr. No.	Name of work	Name and address of the organization for whom the work was done	Place And country	Agreement No. and Date.	Date of Commencement	Tendered cost.	Total cost of work done.	Actual date of completion	Remarks
1	2	3	4	5	6	7	8	9	10
SAMPLE FORM									

Note: This is only a standard form. Details are to be furnished in this format in the form of type written statements which shall be scanned enclosed in envelope No.1 duly signed. The documentary proof of similar type of work done and magnitude should also be scanned and submitted with statement.

CONTRACTOR

No. of correction

REGISTRAR

STATEMENT -IV**STATEMENT SHOWING THE DETAILS OF TECHNICAL PERSONNEL AVAILABLE WITH
CONTRACTOR WHICH CAN BE SPARED EXCLUSIVELY FOR THIS WORK****NAME OF CONTRACTOR:**

Sr. No.	Name of person	Designation.	Qualification	Whether working in field or in office.	Professional Experience of execution of similar works.	Period for which the person is working with the tenderer.	Remarks
1	2	3	4	5	6	7	8
SAMPLE FORM							

Note: This is only a standard form. Details are to be furnished in this format in the form of type written statements, which shall be scanned enclosed in envelope No.1 duly signed. The documentary proof of his Technical persons should also be scanned and submitted with statement.

Signature of Contractor

CONTRACTOR

No. of correction

REEGISTRAR

STATEMENT - V**STATEMENT SHOWING WORK DONE IN RESPECT OF PROVIDING, INSTALLATION
and COMMISSIONING OF VARIOUS LIFTS DURING LAST FIVE YEARS****NAME OF CONTRACTOR:**

Sr. No.	Name of work	Amount put to tender / tendered cost	Agreement No.	Date of Comm encem ent	Amount of work done during each of last five years					Amount of work Still remaining to be executed	Remarks
					2019- 20	2020- 21	2021- 22	2022- 23	2023- 24		
1	2	3	4	5	6	7	8	9	10	11	12
SAMPLE FORM											

Out ward No. and date of certificate issuing authority:

Note: This is only a standard form. Details are to be furnished in this format in the form of type written statements, which shall be scanned enclosed in envelope No.1 duly signed. The documentary proof of work done with whom contractor executed should also be scanned and submitted with this statement.

Signature of Contractor**CONTRACTOR****No. of correction****REGISTRAR**

NAME OF WORK : Supply, installation, testing and commissioning of five Nos. MRL(Machine Room Less) 15 passengers lifts and One No. 10passenger MRL (Machine Room Less) at Administrative Building and Examination Bhavan of Punyashlok Ahilyadevi Holkar Solapur University, Solapur.

GENERAL DESCRIPTION OF WORK

The work of supply, installation, testing and commissioning of MRL (Machine Room Less) 5 (five) Nos. 15 passengers lifts and One No. 10 passenger MRL (Machine Room Less) lift including minor civil work at Administrative Building and Examination Bhavan of Punyashlok Ahilyadevi Holkar Solapur University, Solapur. The MRL lift will be installed from ground, first, second and third floor. The period of completion of work shall be four months including monsoon.

The detail description of work, specification etc. is given under section of detailed requirements and conditions of MRL lift at Pg. LF.01 to LF.29 of this tender.

SCOPE OF WORK

1	MRL	:	Machine room less lift
2	Nos. of lifts	:	15 Passenger : 5 Nos. 10 Passenger : 1 No.
3	Rated speed	:	1.00 Km. / second
4	Total travel distance	:	10.80 mt.
5	Floor to be served	:	Ground, First, Second and Third
6	Nos. of stops	:	4 stops (All stops at one side)
7	Lift pit depth	:	1.65 mt.
8	Type of lift machine	:	Central A.C. servo drive with Micro-Processor simple collective selective control A.C. VVVF

CONTRACTOR

No. of correction

REGISTRAR

DECLARATION OF THE CONTRACTOR

I / We hereby declare that I / We have made myself / ourselves thoroughly conversant with the local conditions regarding all materials and labour on which I / We have based my / our rates for this tender. The specifications, conditions and leads on this work have been carefully studied and understood by me / us before submitting this e- tender. I / we undertake to use only the best materials and of manufacturers listed and attached with this tender and as approved by the University Engineer and the Registrar, PMC and Architect, Punyashlok Ahilyadevi Holkar Solapur University, Solapur or his / their duly authorized assistant during execution of the work and abide by his decisions.

SIGNATURE OF THE CONTRACTOR

CONTRACTOR

No. of correction

REGISTRAR

**AGREEMENT FORM C-
1**

LUMP-SUM TENDER & CONTRACT FOR WORK

PUNYASHLOK AHILYADEVI HOLKAR SOLAPUR UNIVERSITY, SOLAPUR.

NAME OF WORK : Supply, installation, testing and commissioning of five Nos.

MRL (Machine Room Less) 15 passengers lifts and

**One No. 10 passenger MRL (Machine Room Less) including minor
civil work at Administrative Building and Examination Bhavan of
Punyashlok Ahilyadevi Holkar Solapur University, Solapur.**

GENERAL RULES & DIRECTIONS FOR THE GUIDANCE OF CONTRACTORS –

1. All works proposed to be executed by contract shall be notified in a form of invitation to tender Online e-Tendering System also pasted on a board hung up in the office of University Engineer and signed by the Registrar, Punyashlok Ahilyadevi Holkar Solapur University, Solapur.

This form will state the work to be carried out as well as the date for submitting and opening tenders and time allowed for carrying out the work as per e-tendering schedule, also the amount of earnest money to be deposited with the tender, and the amount of the security deposit to be deposited by the successful tenderer and the percentage, if any, to be deducted from bills. Copies of the specifications, designs and drawings, estimated rates, schedule rates and any other documents required in connection with the work shall be signed by the University Engineer for the purpose of identification and shall also be open for inspection by contractors at the office of the University Engineer, during office hours.

Where the works are proposed to be executed according to specifications given in the tender document in addition to lift agency and approved by a competent authority on behalf of the **Registrar, Punyashlok Ahilyadevi Holkar Solapur University, Solapur payable at Solapur** such specifications with designs and drawings shall form part of the accepted tender.

2. In the event of the tender being submitted by a firm.
 - 2.(a) The contractor shall pay as per e-tendering schedule sum of **Rs. 97,000/-** (Rupees Ninety Seven Thousand only) as and by way of earnest money online.
 - 2.(b) In the event of his tender accepted, subject to the provisions of Sub- clauses (iii) below, the said amount of earnest money shall be appropriated towards the amount of security deposit payable by him under conditions of General conditions of contract.
 - 2.(c) If after submitting the tender, the contractor withdraws his offer, or modifies the same or if after the acceptance of his tenders the contractor fails or neglect to furnish the balance of security deposit without prejudice to any other rights and powers of the university, hereunder or in law university shall be entitled to forfeit the full amount of the earnest money deposited by him.
 - 2.(d) In the event of his tender not being accepted, the amount of earnest money deposited by the contractor, shall unless it is prior thereto forfeited under the provisions of sub clause (c) above, refunded to him on his passing receipt therefore.

CONTRACTOR

No. of Correction

REGISTRAR

3. Receipt for payments made on account of any work, when executed by a firm, shall also be signed by all the partners, except where the contractors are described in their tender as firm, in which case the receipts shall be signed in the name of firm by one of the partners, or by some other person having authority to give effectual receipts for the firm.
4. Any person who submits a tender shall fill up the usual printed form stating at what percentage above or below the rates specified in Schedule 'B' (Memorandum showing item of work to be carried out) he is willing to undertake the work. Only one rate or such percentage on all estimated rates/scheduled rates shall be named tenders which purpose any alteration in the work specified in the said form of invitation to tender, or in the time allowed for carrying out the work, or which contain any other conditions, of any sort will be liable to rejections. No printed form of tender shall include a tender for more than one works but if contractors who wish to tender two or more works, they shall submit separate tender for each work. Tender shall have the name and number of the work to which they refer, written outside the envelope.
5. **The Registrar, P u n y a s h l o k A h i l y a d e v i H o l k a r Solapur University, Solapur** shall open tenders as per the e-tender schedule and intimated results through e-mail. In the event of a tender being accepted, the contractor shall, for the purpose of identification, sign copies of the specifications and other documents mentioned in Rule. 1.

In the event of tender being rejected, the University Engineer shall refund the amount of the earnest money deposited, to the contractor making the tender, on his giving a receipt for the return of the money.

6. The officer competent to dispose of the tender shall have the right of rejecting all or any of the tenders without assigning any reason.
7. No receipt for any payment alleged to have been made by a contractor in regard to any matter relating to this tender or the contract shall be valid and binding on Government unless it is signed by Registrar.
8. The memorandum of work to be tendered for and the schedule of material to be supplied by university and there rates shall be filled in and completed by the office of the University Engineer, before the tender form is issued. If a form issued to an intending tenderer has not been so filled in and completed he shall request the said office to have this done before he completes and delivers his tender.
9. All works shall be measured net by standard measure and according to the rules and customs adopted by the Public Works Department and without reference to any local custom.
10. Under no circumstances shall any contractor be entitled to claim enhanced rates for any items in this contract.
11. Every registered contractor should produce along with his e-tender certificate of Registration as approved contractor in the appropriate class and renewal of such registration with date of expiry. (Copies to be attested by a Gazette Officer)

CONTRACTOR

No. of correction

REGISTRAR

12. All corrections and additions or pasted slips should be initialed.
13. The measurement of work will be taken according to the usual methods in use in the Public Works Department and no proposals to adopt alternative methods will be accepted. The University Engineer's decision as to what is the usual method in use in the department will be final.
14. The tendering contractor shall furnish a declaration along with the tender showing all works for which he has already entered into contract and the value of work that remains to be executed in each case on the date of submitting the tender.
15. Every tenderer shall scan along with electronic tendering system, information regarding the income tax circle or ward of a district in which he is assessed to income tax, the reference to the number of assessment year.
16. No foreign exchange would be released by the University for the Purchase of plant and machinery required for the execution of the work contracted.
17. The contractor will have to construct shed for storing controlled and valuable materials brought by him at the work site at contractor's cost. The material will be taken for use in the presence of the departmental person. No material will be allowed to be removed from the site of work.
18. The contractors shall also give a list of machinery in their possession and which they propose to use on the work in the form of statement No. II
19. Every registered contractor should furnish along with tender a statement showing previous experience and technical staff employed by him in the form of specimen given.
20. Successful tenderer will have to produce to the satisfaction of the accepting authority a valid and current license issued in his favors under the provision of Contract Labors (Regulation and Abolition Act 1970) before starting work, failing which acceptance of the tender will be liable for withdrawal and earnest money will be forfeited by the university.
21. The contractor shall comply with the provision of the Apprentices Act 1961 and Rules and Order issued there under from time to time. If he fails to do so, his failure will be a breach of contract and Registrar may in his discretion cancel the contract. The contractor shall also be liable for any pecuniary liability arising on account of any violation by him of the provisions of the Act.

CONTRACTOR

No. of correction

REGISTRAR

TENDER FOR WORKS

1. I / we hereby tender for the execution, for the university (herein before and herein after referred to as owner /Registrar of the work specified in the under written memorandum within the time specified in such memorandum at _____ (memorandum showing items of work to be carried out) and in accordance in all respects with the specifications, designs, drawings and instructions in writing referred the conditions of the contract.

MEMORANDUM

a) It several sub works are included they should be detailed in a separate list	a) Name of work	Supply, installation, testing and commissioning offive Nos. MRL (Machine Room Less) 15 passengers lifts and One No. 10 passenger MRL(Machine Room Less) at Administrative Building and Examination Bhavan of Punyashlok Ahilyadevi Holkar Solapur University, Solapur.
	b) Estimated cost	Rs. 97,00,000/-
	c) Earnest money	Rs. 97,000/-
b) Security Deposit	Percentage if any to be deducted from bills so as to make up the total amount required as security deposit by the time, half the work, asmeasured by the cost is done.	5% of accepted tender cost
c) Completion period	4 calender months including monsoon for five lifts and 3 calender months including monsoon for one lift	

CONTRACTOR

No. of correction

REGISTRAR

- 2 I / We agree that the offer shall remain open for acceptance for a minimum period of 120 days from the date fixed for opening the “same” means envelope No. 2 and thereafter until it is withdrawn by me / us by notice in writing duly addressed to the authority opening the tenders and sent by registered post AD or otherwise delivered at the office of such authority university receipt no.

The amount of earnest money shall not bear interest and shall be liable to be forfeited by the university, should I / we fail to (i) abide by the stipulation to keep the offer open for the period mentioned above or (ii) sign and complete the contract documents as required by the engineer and furnish the security deposit as specified in item (d) of the memorandum contained in paragraph 1 above within the time limit laid down in clause (1) of the annexed general conditions of contract. The amount of earnest money may be adjusted towards the security deposit or refunded to me / us if so desired by me / us in writing, unless the same or any part thereof has been forfeited as aforesaid.

3. Should this tender be accepted I / we hereby agree to abide by and fulfill all the terms and provisions of the conditions of contract annexed hereto so far as applicable and default thereof to forfeit and pay to university the sum of money mentioned in the said conditions.

CONTRACTOR

No. of correction

REGISTRAR

VOLUME
IPART II

2 GENERAL CONDITIONS OF CONTRACT

2.1. INTERPRETATIONS AND DEFINITIONS

2.1.1. SINGULAR AND PLURAL

Where the context so requires words importing the singular shall also mean the plural and viceversa.

2.1.2. HEADING AND MARGINAL NOTES TO CONDITIONS

Heading and / or marginal notes to these conditions shall not be deemed to form part thereof or be taken into consideration in the interpretation or construction thereof or the contract.

2.1.3. GENDER

Words importing the masculine gender shall also include the feminine gender.

2.1.4. WORDS IMPORTING PERSONS

Words importing persons include Firms, Companies, Corporations and together bodies, incorporated or not.

7.2. DEFINITIONS:-

2.2.1. In the "Contract" (as herein after defined the following works and expressions shall have the meanings herein assigned except where otherwise specified.

2.2.2. **Contract:** The contract document consists of the Invitation to tender, Opening of Tender, The Agreement, the General Instructions to Contractors, General Conditions of contract, Special Conditions of Contract, Specifications, the drawings, and Bills of Quantities, including all modifications thereof incorporated in the documents before their execution. The contract document is complementary, what is called for in one shall be as binding as it called for by all.

The contract document is complementary, what is called for in one shall be as binding as if called for by all.

The Registrar :

The University Engineer :

The Site Engineer :

The Architect:

The PMC:

The Contractor :

Are those mentioned as such in the Agreement and shall include their legal representatives, assigns or successors. They are treated throughout the Contract Document as if each were of the singular number and masculine gender.

2.2.3. The Employer / owner shall mean PUNYASHLOK AHILYADEVI HOLKAR SOLAPUR UNIVERSITY, SOLAPUR.

2.2.4. The "**Registrar**" means, The Registrar, PUNYASHLOK AHILYADEVI HOLKAR SOLAPUR UNIVERSITY, SOLAPUR.

2.2.5. The "Contractor" shall mean _____
_____ or company

2.2.6. **THE SENATE:** - It is the Senate of the PUNYASHLOK AHILYADEVI HOLKAR SOLAPUR UNIVERSITY, SOLAPUR.

2.2.7. **THE MANAGEMENT COUNCIL:** - It is The Management Council of PUNYASHLOK AHILYADEVI HOLKAR SOLAPUR UNIVERSITY, SOLAPUR. The decisions taken by the University Building and Works Committee shall be placed to the Management Council for 'final' decision and their decision shall be final and without appeal and binding to the contractor.

CONTRACTOR

NO. OF CORRECTION

REGISTRAR

2.2.8 UNIVERSITY BUILDINGS AND WORKS COMMITTEE: - It is the University Building and Works Committee constituted as per Building and works committee ordinances framed under the Maharashtra University Act 1994, amended and latest updated from time to time and also updated by latest resolutions of Management Council and The Maharashtra Non-Agriculture Universities Common Account Code made applicable by the Govt. of Maharashtra w.e.f. 01st April, 2012 to have the procedure consistent with PWD manual. It works under direct and overall Superintendence of the Management Council, have overall control for the Execution of Works and it shall exercise general supervision over the work of engineering staff of the University.

The Committee shall be competent to accord administrative approval, Technical Sanction and financial sanction. The selection of Contractor and acceptance of tender shall be as per the decision of the committee or of the Vice-Chancellor. The decision taken by the Vice-Chancellor or by the building and works committee shall be final and without appeal and binding to the contractor.

2.2.9. **THE CHANCELLOR & GOVERNOR :-** The Governor of Maharashtra, shall be the Chancellor of every University and the Chancellor, by virtue of his office, shall be the Head of the University.

2.2.10. **THE VICE-CHANCELLOR:-** The Vice-chancellor means The Vice-chancellor of PUNYASHLOK AHILYADEVI HOLKAR SOLAPUR UNIVERSITY, SOLAPUR. He is the Chairman of the Building and Works Committee and of The Management Council. The decision taken by the Vice-Chancellor shall be fixed and binding and without appeal to the contractor.

2.2.11. **THE REGISTRAR:** - The Registrar means the Registrar of Punyashlok Ahilyadevi Holkar Solapur University, Solapur. He is the member and Secretary of the Building and Works Committee and administer the contract as a owner. He is also termed as owner in this claimed document.

2.2.12. **THE FINANCE AND ACCOUNTS OFFICER:** - The Finance & Account Officer means the Finance & Account Officer of Punyashlok Ahilyadevi Holkar Solapur University, Solapur. He is the member of the Building and works committee.

2.2.13. **THE UNIVERSITY ENGINEER:** - "UNIVERSITY ENGINEER" means University Engineer or his representative of Punyashlok Ahilyadevi Holkar Solapur University, Solapur. He is overall in-charge for day to day execution of the project. The University Engineer shall have under his control various engineers, site engineers, supervisors, clerks, and other supporting staff and through them, he shall maintain & obtain progress report from the contractor & monitor day to day progress of work at site as per bar-chart.

2.2.13.1. He shall keep the PMC and the Architect well informed for all activities related to the projects for his guidance, advice and necessary actions as per the contract condition.

2.2.13.2. He shall provide the PMC and Architect by providing necessary site data, documents required in respect of the projects, etc.

2.2.13.3. He shall provide the latest P.W.D. Government G.R., circulars etc. to the Architect.

2.2.13.4. He shall also issue site instructions / clarifications necessary actions under various contract conditions as a representative of the University, if required in the interest of the project with the PMC and Architect.

2.2.13.5. The term referred in this agreement at places as "University Engineer" shall be referred as "University Engineer" who shall carry on his duties for the best administration / execution of this contract.

2.2.13.6. Where, PMC is not appointed and the work is executed directly under the supervision of University Engineer, the powers as given under PMC are vested with the University Engineer and the University Engineer be read also as PMC in this agreement.

2.2.14. **THE SITE ENGINEER:** - The Site Engineer means the Site Engineer of Punyashlok Ahilyadevi Holkar Solapur University, Solapur and shall be wholly responsible for day to day execution of the project. He shall check 100% measurements on site with all hidden measurement. He shall work under the direct control of the University Engineer and shall be responsible for him and report every day's progress to them. He shall be totally responsible for getting the work done from the contractor as per the drawings and the specifications. He shall study all the drawings well in advance before execution of the work and if any discrepancy observed must be immediately brought to the notice of the University Engineer who there inform to the University, so that the clarification from the University

Engineer be obtained will in advance before starting the said work. He shall obtain program of work and completion program from the contractor. He shall monitor day- to-day progress of work at site as per bar chart. He shall provide complete necessary data as competitive market rates, leads of materials, labour contents, sundries and whatever information data's required etc. for analyzing non-schedule items, etc.

The term referred in this agreement at places as "Site Engineer" shall be referred as "site Engineer" who shall carry on his duties for the best admission / execution of this contract.

2.2.15. **THE ARCHITECT** :- The "Architects" shall mean the Architects, Design Group (India), 11/12/13, RNA Arcade, Main road, Lokhandwala Complex, Andheri West, Mumbai – 400 053 and shall include their assigns and legal representatives in the event of ceasing to be Architects, such other person / firm / company as shall be nominated by the employer for that purpose shall function as Architects.

2.2.16. PMC : Project Management Consultant

The project management consultant shall mean project management consultant

M/S DESIGN GROUP (INDIA) and shall include their assigns and legal representatives and in the event of ceasing to be PMC, such other person / firm / company as shall be nominated by the employer for that purpose shall function as PMC.

2.2.17. The term "Sub-Contractor" as employed herein, includes those having a direct contract with the Contractor and it includes one who furnishes material worked to a special design according to the plans or specifications of this work but does not include one who merely furnishes material not so worked. Anyone doing working on a piece rate basis shall be deemed a Sub-Contractor.

Where the Contractor in the ordinary course of his business directly carried out works for which Prime Cost or Provisional Sums are included in the Contract Bills and the University Engineer / PMC / Architect is prepared to receive tenders from the Contractors for such items, then the Contractor shall be permitted to tender for the same or any of them but without prejudice to the Owner's right to reject the lowest or any tender. If the Contractor's tender is accepted he shall not sub-let the work without the consent in writing of the University Engineer / Architect.

2.2.18. "**Nominated Sub-Contractor**" shall mean all specialist merchants, tradesmen, and other executing any works or supplying and fixing any goods, who may be nominated or selected by the University Engineer / Architect shall be deemed to be Sub-Contractors employed by the Contractors and are to be referred as nominated Sub-Contractors.

2.2.19. "**Nominated Supplier**" shall mean all specialists, merchants, suppliers and others executing any special order for supplying of materials or equipment, who may have been or be nominated or selected by the University Engineer / Architect. They shall be employed by the contractor.

2.2.20. **The "Works"** shall mean the works to be executed in accordance with the contract or part(s) thereof as the case may be and shall include all extra or additional, altered or substituted works as required for performance of the contract.

2.2.21. "**Temporary works**" shall mean all temporary works of every kind required for or in connection with the execution, of the work tendered, but which will not form part of the letter.

2.2.22. "**Urgent Works**" shall mean any measures which, in the opinion of the PMC / University Engineer / Architect become necessary during the progress of works to obviate any risk or accident or failure which become necessary for security of the work or the persons working, thereon.

2.2.23. **Written Notice** :- Written Notice shall be deemed to have been duly served if delivered in person to the individual or to a member of the firm or to an officer of the corporation for whom it is intended, or if delivery receipt obtained or sent by registered mail to the last business address known to him who gives the notice. The work of the contractor or sub - contractor includes labour of material or both.

2.2.24. The law of the place Solapur of work shall govern the construction place Solapur under this contract.

2.2.25. **Virtual Completion** :- "Virtual Completion" shall mean that the "Works" are completed in every respect in conformity with the Contract Documents and to the full satisfaction of the University Engineer / PMC / Architect including complying all statutory condition, permissions, complying all contract conditions as stated in conditions of contract.

- 2.2.26. **Working Day** : - “Working Day” shall mean any day from Monday to Saturday (both days inclusive) excluding all Public Holidays as notified by the State Government.
- 2.2.27. **A “Week”** shall mean seven consecutive days without regard to the number of hours worked in any day in that week.
- 2.2.28. The “Contract Sum” shall mean the sum for which the tender is accepted.
- 2.2.29. **Approved Equal**: - “Approved Equal” shall mean equivalent approved by the University Engineer / PMC / Architect. Where the context so requires, words written singular only also include the plural and vice-versa.

2.3. THE REGISTRAR, CONTRACTOR AND UNIVERSITY ENGINEER: - The **Registrar**, the Contractor and the University Engineer are those mentioned as such in the Agreement and shall include their legal representative/s assignee/s or successor/s. They are treated throughout the contract documents as if each were the singular number and masculine gender.

2.4. SCOPE AND INTENT :-

- 2.4.1. **Scope** : The general character and the scope of the work is illustrated and defined by the Specifications and the Bills of Quantities herewith attached and by the signed Drawings. If the Contractor shall find any discrepancy in or divergence between the Contract Drawings and or the Contract Bills he shall immediately inform the University Engineer / PMC / Architect specifying the discrepancy or divergence and the University Engineer / PMC / Architect shall issue instruction in regard thereto.
- 2.4.2. **Extent**: - The Contractor shall carry out and complete the work in every respect in accordance with this Contract and with the directions of and to the reasonable satisfaction of the University Engineer / PMC / Architect. The University Engineer / PMC / Architect may in his absolute discretion and from time to time issue further drawings, details and / or written instructions, written directions and written explanations all of which are collectively referred to as the University Engineer / PMC / Architect. All such drawings and instructions shall be consistent with Contract Document, true developments thereof and reasonably inferable there from. In addition, the University Engineer / PMC / Architect may also issue time-to-time instructions / clarification / directions / explanations to the contractor consistent with the contract document with intimation to the University Engineer / PMC / Architect.
- 2.4.3. **Intent**: - The Contract Documents are complementary, and what is called for by any one shall be as binding as if called for by all. The intention of the Document is to include all labour and materials, equipment and transportation necessary for the proper execution of the work. All such drawings and instructions shall be consistent with the Contract Document, true developments thereof and reasonably inferable there from. Materials of work described in words, which so applied, have a well-known technical or trade meaning shall be held to refer to such recognized standard.
- 2.5. **Architects’ Instructions**: - The Architects may from time to time issue further supplementary drawings and / or written instruction, details and directions and explanations which are collectively referred to as the Architects Instructions. The Contractor shall forthwith comply with the duly execute works comprised in such the Architects instructions provided always that verbal instruction, directions and explanations given to the Contractor, or his work’s representative by the Architects shall if involving variation, be confirmed in writing.
- 2.6. If within seven days after receipt of a written notice from the University Engineer / PMC / Architect, requiring compliance with an instruction the Contractor does not comply herewith, then the **Registrar** may employ and pay other persons to execute any work whatsoever which may be necessary to give effect to such instructions and all cost incurred with such employment shall be recoverable from the contractor by the **Registrar** as a debt or may be deducted by him from any monies due to become due to the Contractor under this Contract.
- 2.7 The contractor shall provide the University Engineer / PMC / Architect and their representative every facility and assistance for inspecting the work and materials and for checking and measuring work, time and materials.

CONTRACTOR

No. of corrections

REGISTRAR

- 2.8 The representative of the University Engineer / PMC / Architect shall have power to give notice to the contractor or to his representative of non-approval of any work or materials and such work shall be suspended or the use of such materials shall be discontinued until the decision of the University Engineer / PMC / Architect or the Architects is obtained. The works will from time to time be examined by the University Engineer and the Architects, but such examination shall not in any way exonerate the contractor from the obligation to remedy any defects which may be found to exist at any stage of the works or after the same is completed. Subject to the limitation of this clause the contractor shall take instructions only from the University Engineer / PMC / Architect.
- 2.9 **ARCHITECTS STATUS AND DECISION:** - The Architects shall be the **Registrar**'s representative during the construction period. The Architects shall periodically visit the site and shall have only the general supervision and direction of work and familiarize himself generally with the progress and quality of the work and to determine in general if the work is proceeding in accordance with the Contract Document. He has authority to stop the work whenever such stoppage may be necessary to ensure the proper execution of the work.
- 2.9.1. The Architects shall be in the first instance the interpreter of the conditions of this contract and the judge of its performance. In case of any disputes arising due to the interpretation of any technical terms and conditions of the contract executed between **Registrar** and the Contractor, Specifications and drawings, quality and finish of work acceptance of work and all matters related to this contract document. The Architects decision shall be final who shall give their decision in reasonable time.
- 2.9.2. The Architects may in his absolute discretion and from time to time issue further drawings. Details and /or written instruction, written directions and written explanations and instruction in site instruction book.
- 2.9.3. For other disputes of non-technical nature on the administrative, legal and financial aspects of the contract, the University Engineer shall advise the **Registrar** to arrive at reasonable settlement keeping in view contract condition. Decision of the **Registrar** shall be final and binding on to this contract.
- 2.9.4. The instruction book will be maintained on site which will be in the custody of the representative of the University Engineer / PMC / Architect in which the site instruction / orders will be written and issued to the contractor. The contractor has to accept the instructions. However if he has some observation on the instruction he can write letter to the University Engineer / PMC / Architect within three days.
- 2.9.5. Access for the PMC / University Engineer / the Architects to the Works : The University Engineer / PMC / Architect and their representative shall at all reasonable times have access to the Works and to the Workshops or other places of the Contractor where work is being prepared for the contract and when work is to be so prepared in workshops or other places of sub-contractor, the contractor shall by a term in the sub-contract so far as possible secure a similar right of access to those workshops or places for the University Engineer / PMC / Architect and their representatives and shall do all things reasonably to make such right effective.

2.10. PMC'S STATUS AND DECISION

- 2.10.1. The PMC shall be the Owner's extended arm and representative during the construction period. He shall provide full time supervision at site, monitor the works quality / progress, co-ordinate the work of different agencies give directions to the contractor, measure and certify the work. In case of any dispute arising due to interpretation of conditions of contract, technical matters, specifications and drawing, the PMC shall consult the Architect before giving the decision. The decision of University Engineer / PMC / Architect on quality finish of work acceptance of work shall be final binding on the contractor. The site instruction book will be maintained on site which will be in the custody of representative of PMC, in which the site instructions / orders will be written and issued to the contractor. The contractor can not refuse the site instruction and the contractor has to accept the site instruction.
- 2.10.2. For other disputes of non-technical nature on the administrative, legal and financial aspects of the contract, the PMC shall advise the Registrar to arrive at a reasonable settlement with following Contract Conditions.
- 2.10.3. The University Engineer / PMC / Architect and their representative shall have access to the works at any time. PMC shall study all other drawings well in advance before execution of work and if any discrepancy observed shall bring to the notice of Architect. PMC shall ensure that the construction is done as per the latest Architectural and structural design drawings issued time to time.

- 2.11. ASSIGNMENT:-** The contractor shall not directly or indirectly assign the contract or any part thereof or any benefit or interest herein or thereunder (otherwise than a favour of the contractor's Bankers of any monies due or to become due under the contractor) without the prior written consent of the University Engineer.

CONTRACTOR

NO. OF CORRECTION

REGISTRAR

- 2.12. SUB-LETTING :-** The contractor shall not sub-let the whole or any part of the works without the prior written consent of the University Engineer / PMC / Architect and such consent of the University Engineer / PMC / Architect and such consent, if given, shall not relieve the contractor from any liability or obligation under the contract and he shall be responsible for the acts, defaults and neglects of any sub-contractor, his agents, servants of workmen as if they were the acts, defaults or neglects of the contractor, his agents, servants or workmen provided always that the provision of labour on a piecework basis shall not be deemed to be a sub-letting under this clause.
- 2.13. Sub-Contractors: -** No work of the contract shall be all putted or awarded by the contractor without the sanction of the Registrar. As soon as practicable and before awarding any sub-contract, the Contractor shall obtain approved of the Registrar in writing the names of the Sub-Contractor proposed for the principal parts of the work and for such other parts as the University Engineer / PMC / Architect may direct, and shall not employ any to whom the **Registrar** may have as reasonable objection. The Registrar however, shall have power to obtain estimate and select other agencies to carry out any of the works for which contractor is in default.
- 2.14. Nominated Sub-Contractor: -** As soon as practicable and before awarding work to the nominated sub-contractor, the contractor shall notify the **Registrar** writing the names of the nominated sub-contractor proposed for such parts of the work as the **Registrar** in consultation with the University Engineer / PMC / Architect may direct for his approval.
- 2.14.1** The nominated Sub-Contractor shall carry out and complete the sub-contract work in every respect to the satisfaction of the Contractor and the University Engineer / PMC / Architect and in conformity with all the reasonable direction and requirements of the contractor.
- 2.14.2.** The nominated Sub-Contractor shall observe, perform and comply with all the provisions of this or contract on the part of the Contractor to be observed, performed and complied with so far as they relate and apply to the Sub-Contract works or to any portion of the same.
- 2.14.3.** The nominated Sub-Contractor shall indemnify the Contractor against the same liabilities in respect of the Sub-Contract work as those for which the Contractor is liable to indemnify the **Registrar** under this Contract.
- 2.14.4.** The nominated Sub-Contractor shall indemnify the Contractor against claims in respect of any negligence, omission or default of such Sub-Contractor, his servants or agents or any misuse by him or them of any scaffolding or other plant, and shall insure himself against any such claims and produce the policy, or policies and premium receipts as and when required by the Contractor or the University Engineer / PMC / Architect.
- 2.14.5.** The payment in respect of any work, materials or goods comprised in the Sub Contract shall be made within fourteen days after receipt by the Contractor of the University Engineer / PMC / Architect Certificate under clause under separate contract (Condition No.) of these conditions which states as due an amount calculated by including the total value of such work, materials or goods, and shall when due be subject to the retention by the Contractor of the sums mentioned in sub- item.
- 2.14.6.** The University Engineer / PMC / Architect and their representative shall have right of access to the workshops and other places of the nominated Sub-Contractor.
- 2.14.7.** The Sub-Contract work shall be completed within the period or (where they are to be completed in sections) periods therein specified, that the Contractor shall not without the written consent of the University Engineer / PMC / Architect grant any extension of time for the completion of the Sub-Contract work or any section thereof, and that the Contractor shall inform the University Engineer of any representative made by the nominated Sub-Contractor as to the cause of any delay in the progress of completion of the Sub-Contract work or of any section thereof.
- 2.14.8.** If the nominated Sub-Contractor shall fail to complete the Sub-Contract work or (where the Sub-Contract works are to be completed in sections) any section thereof within the period therein specified or within any extended time granted by the Contractor with the written consent of the University Engineer / PMC / Architect certifies in writing to the Contractor that the same ought reasonably so to have been completed the nominated Sub-Contractor shall pay or allow to the contractor either a sum calculated at the rate therein agreed as Liquidated and Ascertained Damages for the period during which the said work or any section thereof, as the case may be, shall so remain or have remained incomplete or (where no such rate is therein agreed) a sum equivalent to any loss or damage suffered or incurred by the Contractor and caused by the failure of the nominated Sub-Contractor as aforesaid.

- 2.14.9. The Contractor shall retain from the sum directed by the University Engineer / PMC / Architect having been included in the calculation of the amount stated as due in any payment certificate in respect of the total value of work, materials or goods executed or supplied by the nominated Sub- Contractor the percentage of such value retained up to a total amount not exceeding a sum which bears the same ratio to the Sub-Contract price as the unreduced sum named in the appendix to these conditions as limited or Retention Fund bears to the Contract sum; and that the Contractor's interest in any sums so retained (by whomsoever held) shall be fiduciary as trustee for the nominated Sub- Contractor (but without obligation to invest); and that the nominated Sub-Contractor's beneficial interest in such sums shall be subject only to the right of the Contractor, and that if and when such sums or any part thereof are released to the nominated Sub-Contractor they shall be paid in full if paid within 14 days of the date fixed for their release in the Sub-Contract.
- 2.14.10. Before issuing any Payment Certificate, the University Engineer / PMC / Architect may request the Contractor to furnish to him reasonable proof that all amounts included in the calculation of the amount stated as due on previous certificates in respect of the total value of work materials or goods executed or supplied by any nominated Sub-Contractor have been duly discharged and if the Contractor fails to comply with any such request the University Engineer / PMC / Architect shall issue a certificate to that effect and thereupon the **Registrar** may himself pay such amounts to any nominated Sub-Contractor concerned and deduct the same from any sums due or to become due to the Contractor.
- 2.14.11. The Contractor shall not grant to any nominated Sub-Contractor any extension of the period within which the Sub-Contract work or (where the Sub-Contract works are to be completed in sections) any section thereof is to be completed without the written consent of the University Engineer / PMC / Architect of any representation made by the nominated Sub-Contractor as to the cause of any delay in the progress or completion of the Sub-Contract work or any section thereof and that the consent of the University Engineer / PMC / Architect shall not be unreasonably withheld.
- 2.14.12. If any nominated Sub-Contractor fails to complete the Sub-Contract work or (where the Sub-Contract works are to be completed in sections) any section thereof within the period specified in the Sub-Contract or within the extended time granted by the Contractor with the written consent of the University Engineer / PMC / Architect then if the same ought reasonably so to have been completed the University Engineer / PMC / Architect shall certify in writing accordingly. Any such certificates shall be issued to the Contractor and immediately upon issue the University Engineer shall send a duplicate copy thereof to the nominated Sub-Contractor.
- 2.14.13. If the University Engineer / PMC / Architect desires to secure final payment to any nominated Sub-Contractor before final payments is due to the Contractor, and if such Sub-Contractor has satisfactorily indemnified the Contractor against any latent defects then the University Engineer may in an interim Certificate include an amount to cover the said final payment and thereupon the Contractor shall pay such nominated Sub-Contractor the amount so certified. Upon such final payment the amount of retention fund shall be reduced by the sum which bears the same ratio to the said amount as does such Sub-Contractor's Sub-Contract price to the Contract Sum, and save for latent defects the Contractor shall be discharged from all liability for the work materials or goods executed or supplied by such Sub-Contractor under the Sub-Contract to which the payment relates.
- 2.14.14. Neither the existence nor the exercise of the foregoing powers nor anything else contained in these conditions shall render the **Registrar** in any way liable to any nominated Sub-Contractor.
- 2.14.15. Where the Contractor in the ordinary course of his business directly carried out works for which Prime Cost or Provisional Sums are included in the Contract Bills and the University Engineer / PMC / Architect is prepared to receive tenders from the Contractors for such items, then the Contractor shall be permitted to tender for the same or any of them but without prejudice to the **Registrar**'s right to reject the lowest or any tender. If the Contractor's tender is accepted he shall not sub-let the work without the consent in writing of the University Engineer / PMC / Architect.
- 2.14.16. The Contractor shall allow for general attendance upon Sub-Contractors including free use of plant scaffolding and is to allow them the use of sanitary convenience, storage facilities for storing materials, other amenities and affording them all reasonable facilities for carrying out their Contracts.
- 2.14.17. The liability for workmanship, guarantee, defects liability and completion of work in time shall rest with the contractor who shall be held fully responsible in respect of the work carried out through the Sub-Contractors as well as the Nominated Sub-Contractors.

2.15. PRIME COST

- 2.15.1. The following provisions of these conditions shall apply where Prime Cost sums are included in the Contract Bills or arises as a result of the University Engineer / PMC / Architect instructions given in regard to the expenditure of provisional sums in respect of any materials or goods to be fixed by the Contractor.

CONTRACTOR

NO. OF CORRECTION

REGISTRAR

- 2.15.2. Such sums shall be understood to mean the net cost to be defrayed as a Prime Cost after deducting any trade or other discount and shall include sales-tax (where applicable) and other taxes and duties and the cost of packing carriage and delivery. Provided that where in the opinion of the University Engineer / PMC / the Contractor has incurred expense for special packing or special carriage such special expense shall be allowed as per of the sums actually paid by the contractor.
- 2.15.3. Such sums shall be expended in favour of such persons as the University Engineer / PMC / Architect shall instruct, and all specialist, merchants, tradesman or others who are nominated by the University Engineer / PMC / Architect to supply materials or goods are hereby declared to be the suppliers to the Contractor and are referred to in these conditions as "Nominated Suppliers" provided that the University Engineer / PMC / Architect shall not (save where the University Engineer / PMC / Architect and Contractor shall otherwise agree) nominate as a supplier a person who will not enter into a Contract of sale which provides (inter alia).
- (a) That the materials or goods to be supplied shall be to the reasonable satisfaction of the University Engineer / PMC / Architect.
- (b) That the nominated supplier shall make good by replacement or otherwise any defects in the materials or goods supplied which appear within such period as is therein mentioned and shall bear any expenses reasonably incurred by the Contractor as a direct consequence of such defects, provided that where the materials or goods have been used or fixed such defects are not such that examination by the Contractor ought to have revealed them before using or fixing.
- (c) The delivery of the materials of goods supplied shall be commenced and completed at such times as the Contractor may reasonably direct.
- (d) All payments by the Contractor for materials or goods supplied by a Nominated Supplier shall be in full, and shall be paid within 30 days of end of the month during which delivery is made.

2.16. TIME OF COMPLETION: - All time limits stated in the contract document shall be of the essence of the contract. The contractor obligates himself to complete the works including completion of different stages of work as stipulated in all respects within the time schedule stipulated in the Agreement subject to any adjustment granted by the University Engineer / PMC / Architects in writing under the conditions of contract. He shall submit to the University Engineer / PMC / Architects periodic progress reports on the first and fifteenth of each and every month.

2.17. CONTRACTOR'S RESPONSIBILITY REGARDING DAMAGE TO PROPERTY AND INJURY TO PERSONS

- 2.17.1. The **Registrar** shall not be liable or responsible for any accident, loss, death, injury or damage of any kind whatsoever happening in the course of the performance of the works herein referred to and in connection therewith to persons and / or property, materials and equipment and the Contractor shall fully indemnify and protect the **Registrar** from and against the same. In addition to the liability imposed by law upon the Contractor for injury (including death) to persons or damage to property by reason of the negligence of the Contractor or his agents, which liability is not impaired or otherwise affected hereby, the Contractor hereby assumes liability for and agrees to save the **Registrar** harmless and indemnify him from every expense, liability or payment by reason of any injury (including death) to person or damage to property, neighbor's property suffered by any act or omission of the Contractor or any of his Sub-Contractors, or any person directly or indirectly employed by any of them or from the control of the Contractor of any part of the premises which is in the control of the Contractor or any of his Sub-Contractors, or any one directly or indirectly employed by either of them, or arising in any way from the works under this contract.
- Further, the contractor hereby agrees and undertakes to indemnify the **Registrar** from any loss or damage or death arising out of the University Engineer / PMC / Architects instruction, without limiting this obligations and responsibilities under this condition, the Contractor shall ensure and obtain at his cost insurance / insurance's against all the foregoing risks or eventualities. The insurance or insurances shall be obtained in favor of the Registrar, PUNYASHLOKAHILYADEVI HOLKAR SOLAPUR UNIVERSITY AS 'INSURED' and policy / policies shall be deposited with the Registrar.
- 2.17.2. The Contractor shall submit original certificates of Insurance so obtained by him in proof of compliance with the above condition, to the Registrar with C.C. to the University Engineer / PMC / Architects and the Contractor shall not proceed with the work until he has received in writing from the University Engineer / PMC / Architect approval of the Certificates of insurance required by the proceeding paragraph. The contractor will not get any payment before submission of prescribed insurance policy in original.
- 2.17.3. The Contractor shall ensure that his Sub-Contractors shall obtain insurances in the same manner and to the same extent, as he is liable to do under this condition and shall produce to the University Engineer / PMC / Architect Certificates Insurance, so obtained by his Sub-Contractors. The Contractor shall indemnify and keep indemnified

the **Registrar** for any claims or demands that may be made against the **Registrar** for loss or damage arising from the performance of contracts by the Sub-Contractors.

These insurances Certificates shall be fully executed and shall state that the policies cannot be cancelled until ten (10) days after written notification of such intent of cancellation has been given to the **Registrar**. All policies shall be with insurance companies acceptable to the **Registrar**.

The contractor shall owe absolute and unqualified liability for anything done or omitted to be done by him and impairing the validity or value of the insurance policy obtained by him. He shall also indemnify the **Registrar** in respect of any costs, charges or expenses arising out of any claims arising there from. The **Registrar** shall be at liberty to and is hereby empowered to deduct cost, charges and expenses arising or accruing from or in respect of any such claim or damage from any sum or sums due to or become due to the Contractor.

- 2.17.4. The Contractor shall continuously maintain adequate protection of all his work, materials, and equipment from damage, destruction or loss and shall protect the works from weather conditions which, in the University Engineer / PMC / Architects, Punyashlok Ahilyadevi Holkar Solapur University, Solapur opinion will be detrimental to the works. In default, the Contractor shall make good at his cost, any such damage, destruction, loss or injury.
- 2.17.5. When so ordered by the University Engineer / PMC / Architects, the Contractor shall suspend any work that may be subjected to damage by climatic conditions.

2.18. LABOUR REGULATIONS

- 2.18.2. The Contractor shall be wholly and solely responsible for full compliance with the provision under all labour laws and / or regulations such as payments of Wages Act, 1936; Minimum Wages Act, 1948; Employees Liability Act, 1938, Workmen Compensation Act, 1923, Industrial Dispute Act, 1947 and the Maternity Benefit Act, 1961 and any modifications thereof or any law relating thereto and rules made there under from time to time and all laws and regulation now in existence and to be imposed later.
- 2.18.3. The Contractor shall his own expense comply with or cause to be complied with Model Rules for labour welfare framed by Government or other local bodies from time to time for the protection of health and for making sanitary arrangements for workers hutments area. In case the Contractor fails to make arrangements as aforesaid, the **Registrar** shall be entitled to do so and recover the cost thereof from the Contractor.
- 2.18.4. If female labour is employed, the Contractor shall make necessary provision at his own expense, for safeguarding and care of small children and keeping them clear of the site of operations. No labour shall reside within the site except authorized guards.
- 2.18.5. In case the Contractor fails to make arrangements and provide necessary facilities as aforesaid, the **Registrar** shall be entitles to do so and recover the cost there of from the Contractor.

(कंत्राटदाराने शासकिय विमा निधीपाशी कंत्राट कामाचा विमा उतरावा म्हणून करारनाम्यात समाविष्ट करावयाच्या अटी)

कंत्राटदारावर सोपविलेल्या कंत्राट कामांचा विमा कंत्राटदारानी विमा संचालनालय, महाराष्ट्र राज्य, गृह निर्माण भवन, २६४, पहिला मजला, कलानगर, समोर, वांद्रे (पूर्व), मुंबई - ४०००५१ (दूरध्वनी क्र.२६५९०४०३/२६५९०६९० व फॅक्स क्र.२६५९२४६१/२६५९०४०३) या कार्यालयापाशी कंत्राटाच्या संपूर्ण रकमेस व कंत्राटाच्या पूर्ण कालावधिसाठी विमा संचालनालयाने निश्चित केलेल्या (उदा. कंत्राटदाराच्या संपूर्ण जोखीम विमा पत्र इ.) विमा पत्राखाली उतरविणे सक्तीचे आहे. तसेच कंत्राटी काम पूर्ण करण्यासाठी नियुक्त करण्यात येत असलेल्या सर्व कामगारांचा विमा कामगार नुकसान भरपाई विमा पत्राखाली उतरविणे अनिवार्य आहे. विमा संचालनालयाच्या व्यतिरिक्त अन्य विमा कंपन्याकडून घेतलेली विमा पत्रे स्विकारली जाणार नाहीत. जर कोणत्याही कंत्राटदाराने उपरोक्त पध्दतीने विमा पत्र न घेता परस्पर विमा कंपनीकडून विमापत्र घेतल्यास शासकिय विमा निधीने कळविलेली विमा हप्त्याची रक्कम कंत्राटदारास कंत्राटकामापोटी देय असलेल्या रकमेतून

- 2.19. Co-Ordination by the Contractor:-** Co-ordination of work and at the commencement of work, and from time to time, the Contractor shall confirm with other contractors Sub-Contractors, persons engaged on separate contracts in connection with the work, and with the University Engineer / PMC / Architect for the purpose of the co-ordination and execution of the various phases of work. The Contractor shall ascertain from the other contractors, Sub-Contractors and persons engaged on separate contracts, in connection with the works, the extent of all chasing, cutting and forming of all opening, holes, grooves etc. as may be required to accommodate the various services. The Contractor shall ascertain the routes of all services and the positions of all floors and wall outlets, traps etc. in connection with the installation of plant, services and arrange for the construction of work accordingly. The breaking and cutting of completed work must not be done unless specifically authorized in writing by the University Engineer / PMC / Architect. All breaking shall be done by the Contractor for Civil work and no work shall be done over broken or patched work without first ascertaining that the broken surface is adequately prepared and reinforced to receive and hold the further work without any cost.
- 2.20. Co-Ordination of Drawings:-** Before commencement of every section of work, the contractor shall correlate all relevant structural, architectural and services drawings, fire fighting works satisfy himself that the information available there from is complete and unambiguous. The contractor shall be responsible for any error / difficulty in execution / damage incurred owing to any discrepancy in the drawings which has been overlooked by him and has been brought to the notice of the University Engineer / PMC / Architect or their representatives.
- 2.21. Entering upon or commencing any portion of work:-** The contractor shall enter upon or commence any portion of work with prior concurrence in writing of the University Engineer / PMC / Architect of his sub-ordinate-in-charge of work. Failing such and authority, the contractor shall have no claim to ask for measurements of or payment for work done.
- 2.22. Co-ordination with other agencies work:-** It should be carefully noted that numerous agencies will be working in this project simultaneously and the contractor shall have to work at every stage in close co-ordination with each of these agencies. He shall have to programme his work accordingly in consultation with other agencies and par sequential requirements as may be decided upon by the University Engineer / PMC / Architect. Simultaneous execution of other components of the work by other agencies may necessitate execution of the work in a particular sequence and this will not be accepted as a ground for delay or excuse of any nature whatsoever and nothing extra will be paid for compliance in accordance with the requirements of this clause.
- 2.23. DEDUCTION FOR RECORRECTED WORK:-** If the University Engineer / PMC / Architect deems it inexpedient to correct work damaged or not done in accordance with the contract, an equitable deduction from the contract price shall be made therefore and the University Engineer / PMC / decision in this respect shall be final.
- 2.24. CORRECTION OF WORK:-** The University Engineer / PMC / Architect shall conduct a final inspection just before the virtual completion of the work and prepare a list of materials, equipment and items of work which fail to confirm to the Contract Specifications. The contractor shall promptly replace and re-execute such items in accordance with the contract and shall bear all expenses of making good all work and the cost of all work of other contractors destroyed or damaged by such replacement or removal. If the contractor fails to remove and replace above rejected materials, equipment and /or workmanship within a reasonable time, fixed by written notice, the **Registrar** may employ and pay other persons to amend and make good such defects at the expense of the contractor. All expenses incurred by the **Registrar** in rectifying the defects including all the damages, loss and expense consequent on the defects shall be recoverable from any amount due or may become due to the Contractor.
- 2.25. VIRTUAL COMPLETION AND DEFECT LIABILITY PERIOD**
- 2.25.1. The work shall be considered as virtually completed by the Contractor, as on fulfilling all the conditions as per clause 7 of section 6 and all other related conditions of the contract of this document. The Defect Liability Period of **Twenty Four months** provided herein shall be reckoned and be effective from the date of final bill duly accepted by the contractor and on obtaining all required undertaking, guarantees, NOCs / clearance of payment of all GST related taxes / charges and on rectifying all defects notified to the contractor from time to time only on complying above virtual completion certificate will be issued to the contractor.

CONTRACTOR

No.s of Corrections

REGISTRAR

- 2.25.2. The Contractor shall make good at his own cost and to the satisfaction of the University Engineer / PMC / Architects all defects shrinkages, settlement or other faults, arising in the opinion of the University Engineer from work or materials not being in accordance with the Drawings or specifications or Schedules of Quantities or the instructions of the University Engineer / PMC / Architect which may appear within one year after completion of work, excepting specialist items such as water proofing and anti-termite treatment etc. which call for longer guarantee periods.
- 2.25.3. Such defects, shrinkage, settlement and other faults shall, upon directions in writing of the University Engineer / PMC / Architect and within such reasonable time as shall be specified therein, be amended and made good by the Contractor, at his own cost, and in case of default the **Registrar** may employ and pay other persons to amend and make good such defects, shrinkages, settlements or other faults, and all damages, loss and expense consequent there on or incidental thereto shall be made good and borne by the Contractor and such damage, loss or expenses shall be recoverable from him by the **Registrar** or may be deducted by the **Registrar** up to the University Engineer / PMC / Architects Certificate in writing from any amount due to the contractor, or the **Registrar** may in lieu of such amending and making good by the contractor, a sum to be determined by the University Engineer / PMC / Architects on recommendation from University Engineer / PMC / Architect equivalent to the cost of amending such work and in the event of the retention amount being insufficient to recover the balance from the Contractor as arrears of land revenue together with any expense the **Registrar** may have incurred therewith.
- 2.25.4. Maintenance during defects liability period: The Contractor shall provide and maintain adequate staff and labour at his own expense to attend to defects arising in the works during the defects liability period of **Twenty Four months** commencing from the date of Virtual Completion certified by the University Engineer or date of final bill whichever is later. He shall attend to the defects pointed out to him expeditiously.

2.26. GUARANTEE

- 2.26.1. Beside guarantees required elsewhere, the Contractor shall guarantee the work in general for **Twenty Four months** from the date of final bill as noted under above clause of Virtual Completion and Defects Liability Period.
- 2.26.2. The Contractor shall submit all required guarantees to the University Engineer / PMC / Architect when requesting certification of accounts for payment by the **Registrar**.
- 2.26.3 All required guarantee shall be submitted to the University Engineer / P MC / Architect in the forms acceptable as a pre-requisite to acceptance and payment.

2.27. CONTRACT DRAWINGS, SPECIFICATION, SCHEDULE OF QUANTITIES

- 2.27.1. In general, the drawings shall indicate dimensions, positions and type of construction; the specifications shall indicate the quantities and the methods; and the Schedule of Quantities shall indicate the quantities and rate for each item of work. However, the above documents being complementary, what is called for by any one shall be as binding as if called for by all. In case of any discrepancies they shall be immediately brought to the notice of the University Engineer / PMC / Architect well in advance before execution.
- 2.27.2. Any work indicated on the Drawings and not mentioned in the Schedule of Quantities or Specifications or vice versa, shall be deemed as though fully set forth in each. work not specifically detailed, called for, marked or specified.
- 2.27.3. No deviation from the Drawings, Specifications and Schedule of Quantities shall be made. The Architect interpretation of these documents shall be final.
- 2.27.4. Errors or inconsistencies discovered in the Plans and Specifications shall be promptly called to the attention of the University Engineer / PMC / Architect for interpretation or correction of University Engineer / P MC / Architect. Local conditions which may affect the work shall likewise be brought to the Architect's attention at once. If, at any time, it is discovered that work is being done which is not in accordance with the approved plans and specifications, the contractor of defective work shall not be a basis for any claim for extension of time. The contractor shall not carry on with the work except with the knowledge of the University Engineer / PMC / Architect or his representative.

CONTRACTOR

No.s. of corrections

REGISTRAR

2.27.5. Figured dimensions on the scale drawings and large-scale details shall govern. Large-scale details shall take precedence over scale drawings. Any work done before receipt of such details if not in accordance with the same shall be removed and replaced or adjusted as directed without expense to the **Registrar**. All dimensions shall be checked at site prior to execution. Any discrepancy, if observed in drawings, the clarification should be obtained from the Architect before execution.

2.27.6. The dimensions where stated do not allow for waste, laps, joints etc. but the contractor shall provide at his own cost sufficient labour and materials to cover such waste, laps, joints etc.

2.28. METHOD OF MEASUREMENT: - Where work done is to be measured, the standard method of measurement in accordance with the standard laid down by the Indian Standard Institute and standard specification of public works and housing department of Govt. of Maharashtra shall be adopted unless otherwise specified. When several components of item work are specifically incorporated together in the wording of an item in the Bills of Quantities, such item will be measured as a composite item comprising of all the components will not qualify for measurement individually, which the standard method of measurement would have otherwise required them to be measured separately. In the event of any dispute with regard to the mode of measurement of the work executed the decision of the University Engineer / PMC / Architect shall be final and binding.

2.29. TOLERANCE: - The Contractor shall exercise every care to ensure that all structural Members are in plumb and true to dimensions called for on the drawings, to receive finishing elements such as doors, windows, fittings, fixtures, equipment and similar items. The details of the above finishing items are based upon allowing tolerance of plus / minus 3 mm. from the given location. Any variations beyond this may require rectification in the structural members or may involve remaking or replacing the finishing elements, fabricated to fit in the openings or spaces, as called for on the drawings. Such rectification shall be carried out by the contractor as directed by the University Engineer / PMC / Architect at no extra cost to the **Registrar**. In case of Separate contracts, the contractor whose work does not conform to dimensions called for, shall be liable for all the expenses which may have to be incurred for rectification or replacements as may be required by the University Engineer / PMC / Architect for the proper installation of the finishing elements. The Architects decision in this respect shall be final and binding on the Contractor.

2.30. INDIAN STANDARDS: - A reference made to any Indian Standard Specifications in these documents, shall imply reference to the latest revision of the standard, including such revisions / amendments as maybe issued by the Indian Standards Institution during the contract and the corresponding clause/s therein shall hold valid in place of those referred to.

2.31. PROTECTION AND CLEANING

2.31.1. The Contractor shall protect and preserve the works from all damage for accident by providing temporary roofs, windows, and door covering, boxing or other contraction as required by the University Engineer / PMC / Architect. This protection shall be provided for all property adjacent to the site as well as on the site.

2.31.2. The Contractor shall properly clean the work as it progresses and shall remove all rubbish and debris from the site from time to time as is necessary and as directed. On completion, the contractor shall ensure that the premises and / or site are cleaned, surplus materials, debris, shades etc., removed areas under floors cleared or rubbish, gutters and drains cleared, doors and sashes eased, locks and fastenings oiled, keys clearly labeled and handed over to the University Engineer so that the whole is left fit for immediate occupation or use and to the satisfaction of the University Engineer / PMC / Architect.

2.32. SUSPENSION OF WORK :- The Contractor shall, on receipt of the order in writing of the University Engineer / PMC / Architect suspend the progress of the work or any part thereof for such time and in such manner as the University Engineer may consider necessary for any of the following reasons: -

2.32.1. On account of not accepting the site instruction and continued non-compliance of the instructions of the University Engineer / PMC / Architect or any other default on the part of the contractor, in such case the University Engineer shall have powers to suspend the payment under the contract. Such suspension of payment may be continued until default shall have been rectified.

2.32.2. For proper execution of the works or part thereof for reasons other than the default of the contractor, or for safety of the works or part thereof.

CONTRACTOR

No. of corrections

REGISTRAR

2.33. ENTRY AT SITE:- It is hereby expressly declared that the entry of the Contractor(s) on the site will be merely as a licensee for carrying out the construction of works under this Agreement, and they shall not, by his/her being allowed such entry on the premises, acquire any right, lien or interest either in the works carried out by them under the Agreement or anything appurtenant or attached thereto and their claim will only be in the nature of money claim found due and payable to them in accordance with the certificates issued by the University Engineer / PMC / Architect under the provisions contained hereafter.

2.34. JURISDICTION: - All matters arising out of or in any way connected with this agreement shall be deemed to have arisen in MAHARASHTRA STATE and only the Courts in Solapur shall have jurisdiction to determine the same.

2.35. POWER OF THE REGISTRAR TO RECOVER ARREARS FROM THE CONTRACTOR :-

All amounts whatsoever which the contractor is liable to pay to the **Registrars** in connection with the execution of the work including the amount payable in respect of (i) materials and / or stores supplied / issued here under by the **Registrar** to the contractor (ii) hire charges in respect of heavy plant, machinery and equipment given or hire, by the **Registrar** to the contractor for execution by him of the work and / or on which advances have been given by the **Registrar** to the Contractor (iii) and any payment due from the contractor on any account to the **Registrar**, shall be deemed to be arrears of Land Revenue and the **Registrar** may without prejudice to any other rights and remedies of the **Registrar**, recover the same from the contractor as arrears or revenue.

2.36. SETTLEMENT OF DISPUTE

The reference is invited to clause 2.9 and clause 2.10 above regarding the Architects status and decision and PMC's status and Decision and that of University Engineer.

If the contractor is not satisfied with the decision given by the University Engineer / PMC / Architect as aforesaid for any disputes, claims and difference arising due to interpretation of any technical terms and conditions of contract executed between the Owner and the Contractor, specification, drawings, quality and finish of work and acceptable of work and all matter related to this contract document, then the contractor may, within thirty days of receipt by him of any such decision / order, appeal against it with full details and justification to the Vice-Chancellor, Punyashlok Ahilyadevi Holkar Solapur University, Solapur who if convinced that prima-fascia, the contractor's claim, rejected by the University Engineer / PMC / Architect is not frivolous and that there is some substance in the claim of the contractor as would merit a detailed examination and place such claim to the Building and Works Committee for suitable decision.

The decision taken by the Building and Works Committee of the Punyashlok Ahilyadevi Holkar Solapur University shall be final and without appeal and binding to the contractor and the Registrar. The contractor and the owner hereby agree that, this clause shall be condition precedent to any right of action under the contract.

The Arbitration is not allowed and the contract does not provide for any provision to arbitration.

2.37 SECURED ADVANCE ON MATERIALS DURING CONSTRUCTION STAGE

2.37.1. The contractor may be considered for payment as secured advance on certain unfixed imperishable material that have been brought to the site in appropriate and reasonable time for incorporation in the work and stored as per prescribed specification to the extent of 70% of cost of such materials. Such advance payment shall be supported by all relevant vouchers, weigh bills, payment receipts, delivery challan, test certificate, measurement books. Such payment shall be based on the basic rates given in C.S.R. 2022-2023. However the rate whichever is lower will be taken for such advance payment and as recommended by the University Engineer / PMC / Architect where the basic rates of materials are not available in C.S.R. the basic rates decided by University Engineer / PMC / Architect shall be applied.

2.37.2. The Contractor is required to furnish Indenture Bond on Rs. 500/- stamp-paper prescribed by the Owner duly executed by the Contractor as directed for such advance payment. The payment of such advances shall be made only on the Certificate of the University Engineer / PMC / Architect .

2.37.3. Such advance will be made only on such imperishable materials which are to be consumed in less than two months time and which will be solely on the discretion of the University Engineer / PMC / Architect and lying unfixed in safe custody and storage at site on stock taking basis every month and the sum thus advanced in one bill shall be fully recovered from the next bill, may be after allowing fresh advance in the next bill on similar basis on the unfixed materials then in the stock at site.

CONTRACTOR

No.s of corrections

REGISTRAR

- 2.37.4. No such advance will be granted in the pre-final bill. The Advance payments on unfixed materials will be treated as on account payment, such materials when paid for, become the exclusive property of the Registrar and shall not be hypothecated to any party or removed from the site regardless of whether accepted or not.
- 2.37.5. The said materials shall remain in the custody of the Contractor until the work is completed and delivered to the Registrar and any loss or damage shall be the sole responsibility of the contractor. An insurance policy against theft, loss or damage by fire, accident and all other causes including acts of God to cover the value of all materials at site for which the contractor at his cost in the name of the Owner. The policy shall be kept in force till the materials are incorporated in the work. The original policy and receipts for premium shall be submitted to the University Engineer / PMC / Architect.
- 2.37.6. Such payments shall be restricted to the approved imperishable materials as fan, fitting without tubes and lamps, cables, wire etc. Secured advance on cement in addition to the above materials will also be considered to the maximum extent of 75% if storage godown and system of storage is as per conditions of the contract and to the satisfaction of the University Engineer / PMC / Architect.
- 2.37.7 The payment in lieu of secured advance shall not exceed to 10% of the estimated cost put to tender at initial stage and thereafter 10% of balance work as per Schedule ' B ' without premium.

3. ADDITIONAL SAFETY CONDITIONS

- 3.1. Excavation and Trenching : All trenches, four feet or more in depth, shall at all times be supplied with atleast one ladder for each 30 meters in length of fraction thereof. Ladder shall be extended from bottom of the trench to atleast one meter above surface of the ground. The side of the trenches which are 1.50 meters or more in depth shall be stepped back to give suitable slope or securely held by timber bracing, so as to avoid the danger of sides collapse. The excavated materials shall not be placed within 1.50 meters of the edges of the trench or half of the depth of the trench whichever is more. Cutting shall be done from top to bottom. Under no circumstances undermining or under cutting shall be done.
- 3.2. Demolition : Before any demolition work is commenced and also during the process of the work.
- a. All roads and open areas adjacent to the work site shall either be closed or suitably protected.
 - b. No electric cable or apparatus which is liable to be a source of danger over a cable or apparatus which is liable to be used by the operator shall remain electrically charged.
 - c. All practical steps shall be taken to prevent danger to person employed from risk of fire or explosion or flooding. No floor, roof or other part of the building shall be so overloaded with debris or materials as to render it unsafe.
- 3.3. All necessary personal safety equipment as considered adequate by the University Engineer / PMC / Architect should be kept available for the use of the person employed on the site and maintained in condition suitable for immediate use and the contractor should take adequate steps to ensure proper use of equipment by those concerned.
- a. Those engaged in welding work shall be provided with welder's protective eyesight lids.
 - b. Stone breakers shall be provided with goggles and protective clothing and seated at sufficiently safe intervals.
 - c. The contractor shall not employ men below the age of 18 years and women on the work of painting with products containing lead in any form. Whenever men above the age of 18 years are employed on the work of lead painting, the following precautions should be taken.
 - i. No paint containing lead or lead products shall be used except in the form of paste or ready-made paint.
 - ii. Suitable face masks should be supplied for use by the worker. As paint is applied in the form of spray on the surface or when paint dry-rubbed and scrapped.
- 3.4. When the work is done near any place where there is a risk of drowning, all necessary equipments should be provided and kept ready for use and all necessary steps taken for prompt rescue of any person in danger and adequate provision should be made for prompt first aid treatment of all injuries likely to be sustained during the course of work.

CONTRACTOR

No. of Corrections

REGISTRAR

- 3.5. The safety provisions should be brought to the notice of all concerned by display on a notice board at a prominent place at work spot. The person responsible for compliance of the safety code shall be named therein by the contractor.
- 3.6. To ensure effective enforcement of the rules and regulations relating to safety precautions, the arrangements made by the contractor shall be open to inspection by the Labour officer, owner, the University Engineer / PMC / Architect.
- 3.7. Notwithstanding all the clauses on safety codes, there is nothing in these to exempt the contractor from the operation of any other Act or rule in force in the Republic of India.

CONTRACTOR

No. of corrections

REGISTRAR

Supply, installation, testing and commissioning of MRL (Machine Room less) One No. 10 (ten) passenger lifts including minor civil work at administrative building and Examination Bhavan at Punyashlok Ahilyadevi Holkar Solapur University, Solapur.

SPECIAL CONDITIONS OF LIFT : 10 PASSENGERS

1. **DETAILED**

REQUIREMENTS GENERAL

SCHEME :

The lift shall be designed to operate either manually i.e. attendant control as well as Automatically i.e. without the attendant control. The automatic control shall be such that every button pressed whether at landing or in the car will register the call and will be answered invariably even if the car is stationary or in motion. The up and down calls from the car shall be answered during the up and down travel of the lift respectively. Only down calls shall be answered in sequence while going down. Further, these calls shall be answered in the order in which floors are reached independent of the sequence in which the buttons are pressed. During the upward journey, the car will stop at appropriate landing from where the calls are made in that direction. If down call is made, from the floor above the last landing served, the car shall travel in the up direction upto the highest floor from where a down call is made. The travel of lift will then reverse automatically and car will continue to go in the down direction till the ground floor is reached, stopping at all intermediate landing in response to calls either from the car or from the landings in that direction. Also if the travel is down and call is made from upper landings lift will not reverse the travel till it reaches down destination and vice versa. The openings of door will be automatic with centre opening. When lift reaches landing, doors will be opened automatically and closing will be controlled by light protection beam. The lift shall be driven by A.C. servo drive control with microprocessor for comfortable starting and stopping and accurate floor levelling smoothly. Automatic system of control shall be further designed to park the lift at ground floor, if no call is received in a period of about 60 seconds after reaching the floor it had last served. Complete most updated system shall be incorporated in the lifts.

The cost of lift should include steel fabrication, scaffolding in minor civil works in lift.

The lift agency shall obtain PWD licence / statutory permission for the operation of lift from competent authority.

Annual comprehensive maintenance charges shall be obtained for next five years from One year + two months of free maintenance period.

You shall provide Fabrication engineering drawing as per site condition.

Actual site measurements shall be taken before making lift fabrication drawing.

2. **TYPE AND RATING :**

The MRL (Machine room less) lifts to be supplied and installed under this contract shall be designed to meet the following requirements :

2.1.	Nos. of passenger	:	10
2.2.	Type of building	:	Education
2.3.	Location	:	Punyashlok Ahilyadevi Holkar Solapur University, Solapur.
2.4.	Type of Lifts	:	Passenger Lifts
2.5.	No. of Lifts	:	ONE Lift
2.6.	Contract Load	:	Suitable for minimum 10 Passengers Generally 680 Kg. or as per standard of lift manufacture ranged upto 1088 Kg.
2.7.	Rated Speed	:	1.0 Metre / Second
2.8.	Total Travel	:	10.80 Mtrs. or as per actual site conditions

2.9.	Floors to be served	:	Four floors G + 3 floors of 3.60 mt. Floor to floor height
2.10.	Handrail	:	in S.S. 304 of size and design as approved by Architect.
2.11.	No. of stops / entrances	:	4 stops (All stops on one side)
2.12.	Service Duty	:	Heavy duty, not less than 120 starts / hr.
2.13.	Type of Lift machine	:	Control A.C. servo drive with micro processor simpler collective selective control, A.C.V.V.V.F.
2.14.	Size of pit	:	2.37 m. x 2.00 m. (should be measured of each lift at site)
2.15.	Depth of lift pit	:	1.70 m. deep (should be measured of each lift at site)
2.16.	Size of the car	:	Suitable for minimum 10 passengers with car sill and floor guard at every floor
2.17.	Size of car door	:	min. 900 to 1000 mm. X 2000 mm. / As per standard for 10 passengers lift.
2.18.	Car Door	:	Auto door opening with hair line finish stainless steel 316
2.19.	Landing doors	:	All in hairline finish stainless steel 304
2.20.	Car	:	Lift interiors will be of hair line finish stainless steel in SS 304 with doors also of same type, fan, fan grills, artificial ceiling. The proper barricade above lift car shall be provided with lighting arrangement for repairs.
2.21.	Flooring	:	Natural granite Z black without any spot or other superior quality granite of shade and colour as approved by Architect / University Engineer
2.22.	No. of landing doors	:	4 (Four)
2.23.	Size of the landing door :		900 to 1000 mm. wide X 2000 mm. high / as per Standard for 10 passengers lift
2.24.	Size of the guides for car:		The Tee Section guides as per the requirements of Bombay Lift Act and I.S. codes.
2.25.	Size of the guides for counter weight	:	Tee section guides as per Bombay Lift Act / I.S. Codes.
2.26.	Safety gear	:	Instantaneous
2.27.	M/C operation	:	Simpler Collective Selective Control, A.C.V.V.V.F. with / without attendant Operation (of latest technology)

- 2.28. Lift Shaft : Width 2.370 mm.
Depth 2.00 mm.
(should be measured at each lift at site)
- 2.29. Control : Simplex Full Collective
- 2.30. Door Type : Automatic opening with S.S. panels, S.S.316
hairline finish and centre opening doors.
- 2.31. Door drive : Frequency converter
Fully controlled, obstacle detection,torque
limitation
- 2.32. Other features : 1. Automatic home landing.
In case of power failure standby
power is readily available to bring
the lift to nearest landing in the
direction of travel and open
the door. Auto rescue device.
2. Light beam door protection system
3. Battery operated press and Talk type
Intercom system consisting of
speaker integrated in car panel
connected to a common master unit
at security desk on Ground Floor
Lift Lobby.
- 2.33. Camera : High end latest model of Hick vision camera
as approved by Architect / University
Engineer with connection to a common
master unit at security desk on Groundfloor
lift lobby

2.34. LIFT MOTOR

The gearless motor shall be of continuous rating heavy duty speciallydesigned
for lift service confirming to ISS under condition of load.

- 2.35. Special features : Automatic Rescue Device
Full length Infra red light curtain to car door
Intercom provision
Digital car position indicators in car andall
landings.
Arrival gong
Ventilation by Blower fan
Battery operated emergency light and alarmVisual
confirmation of call registration Fireman's Service
Attendant Operation as well as automaticOperation
without attendant
Full load / Overload with buzzer & visualindicator
Door open button Phase
Control DeviceCamera in
lift car

Supply, installation, testing and commissioning of MRL (Machine Room less) five Nos. 15 (fifteen) passenger lifts including minor civil work at Administrative Building and Examination Bhavan at Punyashlok Ahilyadevi Holkar Solapur University, Solapur.

SPECIAL CONDITIONS OF LIIFT : 15 PASSENGERS

DETAILED REQUIREMENTS

GENERAL SCHEME :

The lift shall be designed to operate either manually i.e. attendant control as well as Automatically i.e. without the attendant control. The automatic control shall be such that every button pressed whether at landing or in the car will register the call and will be answered invariably even if the car is stationery or in motion. The up and down calls from the car shall be answered during the up and down travel of the lift respectively. Only down calls shall be answered in sequence while going down. Further, these calls shall be answered in the order in which floors are reached independent of the sequence in which the buttons are pressed. During the upward journey, the car will stop at appropriate landing from where the calls are made in that direction. If down call is made, from the floor above the last landing served, the car shall travel in the up direction upto the highest floor from where a down call is made. The travel of lift will then reverse automatically and car will continue to go in the down direction till the ground floor is reached, stopping at all intermediate landing in response to calls either from the car or from the landings in that direction. Also if the travel is down and call is made from upper landings lift will not reverse the travel till it reaches down destination and vice versa. The openings of door will be automatic with centre opening. When lift reaches landing, doors will be opened automatically and closing will be controlled by light protection beam. The lift shall be driven by A.C. servo drive control with microprocessor for comfortable starting and stopping and accurate floor levelling smoothly. Automatic system of control shall be further designed to park the lift at ground floor, if no call is received in a period of about 60 seconds after reaching the floor it had last served. Complete most updated system shall be incorporated in the lifts.

The cost of lift should include steel fabrication, scaffolding in minor civil works in lift.

The lift agency shall obtain PWD licence / statutory permission for the operation of lift from competent authority.

Annual comprehensive maintenance charges shall be obtained for next five years from One year + two months of free maintenance period.

You shall provide Fabrication engineering drawing as per site condition.

Actual site measurements shall be taken before making lift fabrication drawing.

3 TYPE AND RATING :

The MRL (Machine room less) lifts to be supplied and installed under this contract shall be designed to meet the following requirements :

3.1.	Nos. of passenger	:	15
3.2.	Type of building	:	Education
3.3.	Location	:	Punyashlok Ahilyadevi Holkar Solapur University, Solapur.
3.4.	Type of Lifts	:	Passenger Lifts
3.5.	No. of Lifts	:	FIVE Lifts
3.6.	Contract Load	:	Suitable for minimum 15 Passengers Generally 1020 Kg. or as per standard of lift manufacture ranged upto 1088 Kg.
3.7.	Rated Speed	:	1.0 Metre / Second
3.8.	Total Travel	:	10.80 Mtrs. or as per actual site conditions

3.9.	Floors to be served	:	Four floors G + 3 floors of 3.60 mt. Floor to floor height
3.10.	Handrail	:	in S.S. 304 of size and design as approved by Architect.
3.11.	No. of stops / entrances :	:	4 stops (All stops on one side)
3.12.	Service Duty	:	Heavy duty, not less than 120 starts / hr.
3.13.	Type of Lift machine	:	Control A.C. servo drive with micro processor simpler collective selective control, A.C.V.V.V.F.
3.14.	Size of pit	:	2.570 m. x 2.500 m. for four lifts 2.550 x 2.50 : one lift (should be measured of each lift at site)
3.15.	Depth of lift pit	:	1.70 m. deep (should be measured at each lift at site)
3.16.	Size of the car	:	Suitable for minimum 15 passengers with car sill and floor guard at every floor
3.17.	Size of car door	:	min. 900 to 1000 mm. X 2000 mm. / As per standard for 15 passengers lift.
3.18.	Car Door	:	Auto door opening with hair line finish stainless steel 316
3.19.	Landing doors	:	All in hairline finish stainless steel 304
3.20.	Car	:	Lift interiors will be of hair line finish stainless steel in SS 304 with doors also of same type, fan, fan grills, artificial ceiling.
3.21.	Flooring	:	Natural granite Z black without any spot or other superior quality granite of shade and colour as approved by Architect / University Engineer
3.22.	No. of landing doors	:	4 (Four)
3.23.	Size of the landing door :	:	900 to 1000 mm. wide X 2000 mm. high / as per Standard for 15 passengers lift
3.24.	Size of the guides for car:	:	The Tee Section guides as per the requirements of BombayLift Act and I.S. codes.
3.25.	Size of the guides for counter weight	:	Tee section guides as per Bombay Lift Act / I.S. Codes.
3.26.	Safety gear	:	Instantaneous
3.27.	M/C operation	:	Simpler Collective Selective Control, A.C.V.V.V.F. with / without attendant Operation (of latest technology)
3.28.	Lift Shaft	:	Width 2570 mm. for 4 lifts and 2.55 for one lift Depth 2.50 mm. for all lifts (should be measured at each lift at site)

- 3.29. Control : Simplex Full Collective
- 3.30. Door Type : Automatic opening with S.S. panels, S.S.316 hairline finish and centre opening doors.
- 3.31. Door drive : Frequency converter
Fully controlled, obstacle detection,torque limitation
- 3.32. Other features :
 1. Automatic home landing.
In case of power failure standby power is readily available to bring the lift to nearest landing in the direction of travel and open the door. Auto rescue device.
 2. Light beam door protection system
 3. Battery operated press and Talk type Intercom system consisting of speaker integrated in car panel connected to a common master unit at security desk on Ground Floor Lift Lobby.
- 3.33. Camera : High end latest model of Hick vision camera as approved by Architect / University Engineer with connection to a common master unit at security desk on Ground floor lift lobby

3.34. LIFT MOTOR

The gearless motor shall be of continuous rating heavy duty speciallydesigned for lift service confirming to ISS under condition of load.

- 3.35. Special features : Automatic Rescue Device
Full length Infra red light curtain to car door
Intercom provision
Digital car position indicators in car andall landings.
Arrival gong
Ventilation by Blower fan
Battery operated emergency light and alarmVisual confirmation of call registration Fireman’s Service Attendant Operation as well as automatic Operation without attendant
Full load / Overload with buzzer & visualindicator
Door open button Phase
Control DeviceCamera in lift car

4. CAR AND LANDING DOOR OPERATOR

For lift and electric door operator shall be provided to open simultaneously the car and hoist way door when the car is at a landing. Both the doors shall be closed simultaneously by motor power. Emergency key shall be made to open doors outside the hoist way. In case of interruption of electric power or failure of operator it shall be possible to open the doors, manually from within the car and also from outside. An electric contact for the car door shall be provided which shall prevent elevator movement away from the landing unless the door is in the closed position. Each hoist way door shall be equipped with a positive electro mechanical inter lock and auxiliary door closing so that the elevator can be operated only after inter lock circuit is established. The door shall open automatically while the car has levelled at the respective landing. The doors shall automatically close after predetermined time interval has elapsed, but the momentary pressure of the ' Door Open ' button provided in the car shall reverse the motion and re-open the door and rest. Each car door shall be provided with a protective device extending full height and projecting beyond the front edge of the door. This device shall be so arranged that should it touch a person or any obstruction in its patch, while the door is closing it shall automatically open both doors of the car and hoist way to return to the open position.

5. DRAWING AND DATA TO BE SUBMITTED BY THE LIFT CONTRACTOR

5.1. TENDER DRAWINGS AND DATA

The contractors shall furnish the following drawings in addition to the data as per the schedule " The Schedule of Technical Particular and other Data". This schedule must be complete and filled-in, while submitting the tender.

- 5.1.1. The drawings showing the plan of installations of the lift car and counterweight.
- 5.1.2. The drawings showing the plan of installations of lift machine, Controller, etc.as a machine room less lift.
- 5.1.3. Any other drawing (s) technical literature / Photos / cut-views etc. as may be considered necessary by him to demonstrate that the equipment offered by him and layouts proposed meet the requirements of these specifications.
- 5.1.5. Section and plan for lift well showing location details for pockets required for fixing separator channels, angles, necessary recess in wall, R.C.C. buffer blocks sizes, locations, openings to be provided in top slab of lift well for guides with details required for builders work.
- 5.1.6. The drawing shall show the supporting system on the top of Hoist way at ceiling and lift walls duly calculated to support the lift car, counter weight etc. by way of M.S. girders, fabrication system hooks etc. as required for installation of lift which shall be provided & installed by the lift agency and all shall be included in the quoted cost and nothing shall be paid extra.

6. CONTRACT DRAWINGS AND DATA

After the acceptance of the tender, the contractor shall have to furnish four copies of finalised general arrangement drawings.

The contractor shall also furnish a copy of schematic wiring drawing.

The contractor shall furnish a copy of instruction and maintenance manual on the completion of work.

7. **APPLICABLE STANDARDS / STATUTORY REQUIREMENT :**

All works shall be carried out in accordance with relevant Indian Standards specifications and wherever applicable and provision of I.E. Act 1910, and I.E. Rules 1956 (as amended upto date), Further statutory requirements as per Bombay Lift Act 1939, Bombay Lift Rules 1958. The completed work shall be got approved from relevant statutory authorities including lift licence from PWD authorities and shall keep valid licence during the comprehensive maintenance period at no extra cost.

A list of the Indian Standards which shall be applicable are given below :The latest version shall be applicable and shall be adopted.

- 7.1. 1860-1980 - Code of Practice for Installation, operation and maintenance of Electrical Hospital Cum Passenger Lift.
- 7.2. 4666-1980 - Electrical Passenger lift.
- 7.3. 3534-1976 - Out line dimension of Electric Lifts
- 7.4. 7759-1975 - Lift door locking devices and contracts.
- 7.5. 8216-1976 - Guide for inspection of lift wire rope.
- 7.6. 9803-1981 - Specification for buffers for Electric Passenger Lift.
- 7.7. 2365-1977 - Specification for steel wire suspension for lift, elevatorsand hoists.

8. **BUFFERS**

Spring buffers shall be provided for car and counterweight erected on heavy channelsgrouted suitably. It shall be of make approved by Architect.

9. **ROPES**

The hoist ropes shall be specialised quality steel or high grade traction steel of suitable size construction and number of ropes shall ensure the proper operation of the elevator and give satisfactory wearing qualities. The factor of safety shall be not less than 10. The rope shall have no joints and shall be as per lift act. Steel ropes shall be Usha Martin make of size specified by PWD and lift authorities.

10. **OPERATION :**

The operation shall be with and without attendant for the car.

The operating panel in each car shall include a series of push buttons corresponding to the floors served and series of additional push buttons and light jewels as required emergency stop switch and alarm button. A complete operating panel shall be included in such car atone side of the entrance to indicate stops registered by the buttons in the car. The floor button in separating panel shall illuminate and remain illuminated till the stop is cancelled. At each landing served by these elevators there shall be one mechanical button fixture including single button at each landing.

The stops registered by the momentary pressure of the car buttons shall be made automatically in succession as the car reaches the landing irrespective of the sequence in which the buttons are pressed. The sequence of operation shall be repeated at the landingsin down direction for which down calls are registered. When the car reaches the reversepoint the direction circuits shall be reversed automatically so that when doors are closed thecar shall start in the ' DOWN ' direction. During the down car travel all car calls and downlanding calls shall be answered in the same manner as described for the UP trip. A keyswitch shall be included in the main operating panel in each car for switching the elevator toautomatic ' without attendant ' operations or when desired ' With Attendant ' operation.

CONTRACTOR

No. of correction

REGISTRAR

For ' With Attendant ' Operation for the use of a attendant these shall be included in the main operating panel, a Non stop Button to have the car by pass landing calls if desired.

The car door opens automatically on reaching landing. It will close also automatically using light beam sensor feature.

All the upto date technology shall be incorporated in the lift.

11. **HALL BUTTONS WITH POSITION INDICATOR :**

It should consist digital type position indicator, with direction arrows and single push button. Single push button fixtures complete shall be provided at each landing illuminating type or with illuminating LEDS to indicate that the call is registered and shall be combined with digital position indicator with UP and DN directional arrows. On all Floors in addition to push buttons for registering calls, should also have display at the top of lift door opening indicating all floors and it should display the position of lift.

12. **CAR POSITION INDICATOR :**

The car panel shall include digital position indicator with UP / DN direction arrows and it will also show the floor number when it reaches / passes it.

13. **ULTIMATE TERMINAL LIMIT SWITCH**

These shall be provided in accordance with the statutory requirements. They shall stop the car automatically within top and bottom clearances independently of the normal terminal switches but with the buffer operative.

14. **OTHER FEATURES**

14.1. **AUTOMATIC HOME LANDING / AUTO RESCUE DEVICE**

In case of power failure, standby power is readily made available to bring the lift to the nearest landing in the travelling direction and open the doors.

14.2. **LIGHT BEAM PROTECTION SYSTEM**

The system emits invisible light beam. If any beam is interrupted, it will re-open closing doors to prevent user from being caught in doors.

14.3. **INTERCOM FACILITY**

Intercom facility shall be provided in the car, Lift Room and meter room by the lift contractor so that in case the lift stops in between the floors there shall be facility to have a telephonic conversation with the technical staff on duty to attend the break down. (This includes the battery charging unit & battery also).

15. **CONTROL TYPE : COLLECTIVE SELECTIVE CONTROL**

The lift has up and down buttons at each landing to select desired direction of travel. The micro-processor based controller memorises all car and landing calls and lift answers all registered calls sequentially in the direction of movement before reversing its direction.

16. **EMERGENCY CAR LIGHTS**

Emergency lights on battery in car shall be provided.

17. **INSPECTION / OPERATION**

Top of car operating fixture shall be provided with car containing an emergency stop toggle switch for putting the buttons on top of the car in operation.

18. CABLE WORK AND CAR TRAVELLING CABLES

Power wiring between the controller and main board, controller to auxiliary and controller to various landings shall be done in steel troughing with PVC insulated copper wire. All cable work shall conform to I.E. Rule 1956 to the latest rules. Cables for different functions shall not be run in the same conduit.

19. CAR APRON PLATE

These shall be fitted in the car platform such that no gap exists at any time when the landing door is opening to avoid danger. Thresholds sill plates shall also be fitted to the landing wherever required. Landing fascia plate shall also be supplied and fitted at all landings.

20. EARTHING OF METAL WORK

The metal frame work of the motors, controllers and all electrical equipments of the car all other metal frame work shall be effectively earthed as per provision of I.E. Rule 1956 with updated to latest rules.

21 Two numbers protection earthing conductor required from earth pits to earth bar in the controller in machine room less lift (MRL). The total minimum cross section of conductors should be 25 Sq.mm. copper with two numbers copper 8 gauge wire or more as required, should be used.

22. The phase reversal relay and earth fault relay shall be provided.

23. Toggle switch or Fireman's switch - lift shall conform to fire lift rules.

24. INSPECTION AND TESTING

The lift shall be got inspected by the contractor and all official statutory fees as applicable shall be paid by University. However, the University shall pay only official charges of PWD. All compliances mentioned and required by various statutory authorities such as Lift Inspector, Fire officer, P.W.D., local authorities, M.S.E.B. etc. shall be done before and after installation by the Lift contractor without any extra cost within the stipulated completion period and all their approvals shall be submitted to the University Engineer / Architect / PMC.

25. WIRE ROPE

The size, number, construction and fastening of the ropes should be in accordance with the provision of I.S. 2365-1977 (Specification for steel wire suspension) and a recorded statement shall be submitted to the University Engineer / PMC. The make shall as only approved by the University Engineer and PMC.

26. TEST ON SITE

After all the works are properly completed the following tests shall be carried out in the presence of University Engineer / PMC or his representative on each lift installation at the time of statutory inspection. However, all the tests must be taken before inviting the lift inspector and submitted all test report to the University Engineer / PMC.

26.1. SERVICE CYCLE TEST

In order to represent the actual service cycle in practice as nearly as possible, the lifts shall run with contract load factor of safety as per I. S. Specification for about one hour continuously. During this test the lift shall be run ' UP ' direction from ground floor and shall be made to stop at every floor in succession till the highest landing is reached. The stop on each landing during ' UP ' travel shall be adjusted to that in actual service. The lift shall then be taken to ground floor straight without any stop. This shall represent one cycle. The lift shall be run continuously in repeat cycle. The lift shall be run continuously in repeat cycle in this manner for the duration of one hour as stated above.

During the test, an energy meter shall be connected across the supply in order to obtain the total energy consumption of the installation. The contractor should quote the energy consumption for one hour with such condition.

At the end of continuous run, the winding temperature of lift motor shall be measured and recorded. This shall be comparable with the data furnished in the tender.

26.2. FLOOR LEVELLING TEST

At the end of the service cycle test the lift shall be run with contact load in UP direction and made to stop at each landing. The actual distance of the lift stop at each landing shall be recorded.

The lift shall then be taken DOWN, stopping at each landing in run and again the measurements at each floor shall be recorded. The cycle shall be repeated successfully for 180 starts per / hr. The average of minimum 6 readings at each floor shall then considered for the purpose of comparing the accuracy of the levelling guaranteed.

At the end of above, the lift shall be run again in 8 successive cycles but with car empty and similar readings at each floor during ' UP ' & ' DOWN ' travel shall be recorded. The average of these readings shall be comparable with figures stated in the tender.

26.3. SAFETY GEAR TEST

- (a) The lift car shall be run at the contract speed with contract load in the downward direction and the safety gear shall be put into operation the car should stop within the range of stopping distance permissible as per the provision of Bombay Lift Rules.
- (b) It shall be noted that on application of the safety gear whether the car platform becomes out of level in excess of 6 mm. per 800 mm. measured in any direction.
- (c) It shall be noted whether there is any decrease in the tension of anyrope on application of the safety gear.
- (d) It should be permissible to release the safety gear by reversing the direction of the lift machine i.e. moving the lift car slightly upward.
- (e) It shall be observed and noted whether any vibrations of the list carframe exists on application of safety.

26.4. GOVERNOR TRIPPING TEST

The relevant governor tripping test for the rated speed of above 1 mtr. per sec. the maximum governor tripping speed shall be 115% of the rated speed + 0.25 mtrs/sec. and also the minimum governor tripping speed shall be 115% of the rated speed.

26.5. BRAKE TEST

The necessary test for the lift shall be taken with an electrically released,mechanically applied brake capable of stopping the ' UP ' and ' DOWN ' travelling lift with any load upto rated load.

A detailed report of the above tests shall be prepared and submitted in quadruplicate (4 copies) to the Engineer-in-charge for his approval.

26.6. TEST FOR MAXIMUM SPEED & R.T.T.

The test for maximum Rated Speed and RTT be done and results be compared with quoted.

CONTRACTOR

No. of correction

REGISTRAR

- 26.7. Lift Tenderer should give the speciality of his equipment in following proforma and give the calculation of motor HP he has prepared for the 180 Duty cycle.

S.No.	ITEM
1	Drive Machine speed
2	Flywheel
3	Starting current
4	Starts per hour
5	Levelling Accuracy
6	Outer bearing on gear output shaft
7	Oil in gear
8	Coupling between Motor and gear
9	Motor protection
10	Bearing of Motor
11	Techno - Generator
12	Controller
13	Selector
14	Diagnostics
15	Special features - False call cancelled.

27. The tenderers should submit the mechanical, electrical & civil works layout and lift well as per their requirement alongwith the tender.
28. The tenderer shall also quote separately the annual comprehensive maintenance charges for five years to be paid at the end of every quarter of the year. The maintenance charge shall be w.e.f. the expiry of guarantee period i.e. minimum one year and two months from the date, satisfactory testing and commissioning and handing over the original P.W.D. certificate / licence, and date of final bill, whichever is later.
29. Price variation clause is not applicable to this tender. Hence, escalation shall not be paid under this contract.
30. GST shall be reimbursed by the University on executed cost on submission of documentary evidence of payment of GST to the respective authority, however 1% (onepercent) labour welfare tax shall be deducted from every bill.
31. No claim shall be accepted on account of delay including due to the work related to other contractors involved in to project.
32. Lift installation work should be carried out in close co-ordination with other contractors working on site.
33. The contractor shall make required holes in the lift machine room slabs, all slabs, required all fabrication work as for installation of lift, counter weight etc. and finish it as required including other related civil work at no extra cost.

34. PERSONNEL TRAINING

After handing over, the lift, the manufacture / supplier shall arrange training upto two persons of the Punyashlok Ahilyadevi Holkar Solapur University, Solapur by their installation engineer about the handling of the lift and routine maintainance for a period of one week. The contractor shall also train the security persons of Punyashlok Ahilyadevi Holkar Solapur University, Solapur and other related personnel on rescue of passengers in case of power failure / emergency etc.

35. STRUCTURAL / STEEL WORK

The lift contractor shall take in to consideration the site measurements of shaft, machine room, lift pit etc. and all other related areas involved for installation of the lift. The contractor shall take into account while quoting such extra structural / steel work required for such installation and erection. No extra payment shall be made on this account. The shop / fabrication drawings of all six lifts shall be submitted to the University Engineer / PMC for their approval.

36. FINANCIAL CONDITIONS / PAYMENT TERMS

- 36.1. Then applicable GST shall be reimbursed to the lift contractor on submission of receipt of payment of GST.
- 36.2. The quoted cost shall be inclusive of all above and nothing shall be paid extra in whatever account.
- 36.3. You will deposit 2.5% amount of the quoted tender amount as initial security deposit in case the work order is issued.
- 36.4. Remaining 2.5% of the total quoted amount shall be deducted from interim bills @ 5% each bill till we recover the required amount of 5% of contract amount.
- 36.5. You will submit a performance bank guarantee of 10% of total quoted amount valid for 12 + 2 (fourteen) months after completion of work. The security deposit shall be returned after submitting the bank guarantee, while retaining retention money i.e. 2.5% during the guarantee period / defects liability period.
- 36.6. The terms of payment will be as follows.
- | | | |
|-------|--|-----|
| (a) | 30% value as advance on submission of irrevocable bank guarantee from nationalised bank and bill and only on issue of work-order and its confirmation and acceptance from you | |
| (b) | On supply of material, equipment etc.
75% of cost of material as secured advance as per contract conditions pro-rate to the material supplied at site on recommendation of the Punyashlok Ahilyadevi Holkar Solapur University, Solapur (the extent of material of equipment component is considered 80% of the total contract price) i.e. total payment i.e. 75% of 80% = | 60% |
| | 30% of advance given as advance on submission of bank guarantee will be recovered in this stage of payment i.e. the payment at this stage shall be 60% - 30% = 30% | |
| (c) | 25% of contract value on successful completion of erection, testing & commissioning of lift & obtaining PWD licence for safe operation. i.e. cumulative payment at this stage shall be 85%.60% + 25% = 85% | 25% |
| (d) | 10% of the contract value on handing over of the lift against submission of performance Bank guarantee from nationalised bank. | 10% |
| | 85% + 10% = 95% | |
| (e) | Total security deposit is 5% of total executed cost shall be retained till one year and two months of defect liability period from testing, commissioning, handing over and obtaining PWD license and from date of final bill whichever is later. | |
| | 95% + 5% = 100% | |

36.7. OTHER TERMS & CONDITIONS

- (a) The contractor shall furnish the test certificates for machine, motor, speed Governor before despatch of the materials.
- (b) The contractor shall carry out all relevant tests after commissioning the elevator as per Bombay lift act rules ' ISI ' code.
- (c) The inspection of elevators should be carried out from statutory authorities at your cost and copy of the report should be submitted to the client, with valid Lift License. However, the official inspection charges of PWD will be paid by Punyashlok Ahilyadevi Holkar Solapur University, Solapur by cheque or the payment shall be done by the agency as to minimise the time and shall be reimbursed by the University.
- (d) The work should be completed in all respects within four calendar months from the date of work-order.
- (e) The defect liability period shall be for one year and two months after the Successful installation & commissioning of the lift with report from the Inspector of lifts.
- (f) The bills should be submitted in duplicate, which shall be scrutinised by University Engineer and forwarded to the PMC / Architect for technical checking.
- (g) The validity of your tender is 120 days.

37. SERVICE AND MAINTENANCE

- 37.1. The contractor shall provide free comprehensive service and maintenance guarantee for a period of twelve months and two months from the date of handing over the lift as per contract conditions along with valid lift licence and with the date of final bill whichever is later.
 - 37.2. The contractor shall quote separately for yearly comprehensive maintenance contract, against the quarterly installment.
 - 37.3. The maintenance shall consist of regular monthly examination and any necessary adjustment and lubrication of the equipment by competent contractor's technical staff including replacement of damaged parts.
 - 37.4. Upon requests from the Punyashlok Ahilyadevi Holkar Solapur University, Solapur as and when required for rectifying defective functioning, the contractor shall send his technician and put the lift in order without delay.
- 38 The Punyashlok Ahilyadevi Holkar Solapur University, Solapur shall provide Three Phase 415 while the lift contractor shall provide suitable main switches for power as per their requirements including light circuit breakers and other electrical protective devices necessary to meet local requirements and lighting arrangement in the shaft.
- 39 The contractor shall make their own temporary electric connections for the operation of their tools, hoists etc. and three phase 415 V. A.C. power for testing and commissioning of the lift. Alternately, the lift contractor may install temporary electric meter from the meter of main contractor & pay their charges as asked by them. It is totally on mutual consent.
- 40 The Contractor shall do at no extra cost the following :-
- 40.1. Cut pockets and grout car and counter weight guide brackets.
 - 40.2. Cut pockets and grout brackets for over speed Governor and controller.
 - 40.3. Make pockets and grout the rag bolts if required for fixing the over speed governor tension wheel.

- 40.4. Cut pockets and grout landing push and indicator boxes.
- 40.5. Shall make concrete core cutting wherever required.
- 40.6. Any other related works.

**41. SPECIFICATIONS FOR ELECTRICAL INSTALLATION
WORKCODES AND STANDARDS**

41.1. The following codes and standards shall be applicable for the continuous performance of all electrical equipments to be supplied, delivered at site, erected, tested and commissioned.

41.2. The electrical equipments offered shall comply to the relevant Acts or Regulations.

Indian Standard Specifications Fire

Insurance Regulations.

Tariff Advisory Committees Regulations.

And, in particular to Indian Electricity Rules in all respects with other IS Code as applicable at the time of execution over and above the following codes and with all its latest amendments up-to-date.

41.3. Some of the Indian Standards are indicated below for general reference.

IS-5216 : Guide for safety procedures and practices in electricity works IS-5908 :

Method of measurement of electrical installation in building. IS-732 :

Electrical wiring installation (upto 650 volts)

IS-694 : PVC insulated cable and cords for Power / Lighting.

IS-1554 : Part-I PVC insulated cables for working voltages upto 1.1 KV. IS-162

: Electric Power Switchgear for indoor & outdoor Installations. IS-

3427 : Metal enclosed switchgear and control gear.

IS-3043 : Code of practice for earthing.

IS-1567 : Metal clad switches upto 100 Amps. IS-

1293 : 3 pin plugs and socket outlets.

IS-1087 : Single pole tumbler switch 5 Amps.

IS-375 : Marking and arrangement for switchgear Boards
Main Connections and auxiliary wiring.

IS-374 : Ceiling fans IEC

Pub 26: Circuit Breakers

IS-3070 : (Part I) Lightning arrestors.

IS-2675 : Enclosed distribution fuse boards and cut-outs for
voltage upto 1000 volts.

IS-2509 : PVC Electrical Conduits.

IS-2309 : Code of Practice for Lightning Protection.

IS-2312 :	Exhaust fans.
IS-3854 :	Switches for domestic and similar purpose.
IS-8884 :	Installation of electric bells & Call system code of practice.IS-
2268 :	Call Bells / Buzzers.
IS-2208 :	HRC cartridges Fuse units upto 650 volts.
IS-2147 :	Degree of Protection provided for enclosure of switchgear.IS-
1947 :	Flood Lights.
IS-6381 :	Specifications for Construction & testing of electrical apparatus.IS-
5578 :	Guide for marking of insulated conductors.
IS-4613 :	Switch sockets outlets.

Nothing in this specification shall be construed to relieve the conductor of his responsibility to make the installation comply with the requirements of the above.

42. CODES AND STANDARDS

The design, manufacture, testing and supply of the cables under this specifications shall comply with the latest revisions including amendments of the following standards.

IS : 1554 - I	:	PVC insulated heavy duty cables for working voltage upto 1100 Volts.
IS : 3961 - II	:	Recommended current ratings for cables.IS :
8130	:	Conductors for insulated cables.
IS : 5831	:	PVC insulation and sheath of electric cables.IS :
10810	:	Test Procedures for cables.
IS : 10418	:	Specification for drums for electric cables.
IS : 3975	:	Mile steel wire, strips, and tapes for armouring of cables.

SCHEDULE OF TECHNICAL PARTICULARS AND GUARANTEED DATA

SR. No.	DESCRIPTION
------------	-------------

(A) GENERAL

1. Name of manufacturer
2. Address of manufacturer
3. Capacity (Persons / weight)
4. Service

CONTRACTOR

No. of correction

REGISTRAR

5. Speed of Travel
6. Height of Travel
7. No. of floors served
8. No. of openings
9. Position of counter weight
10. Type of Levelling method.

(B) LIFT MACHINE

I. DRIVE

1. Type of drive and speed
2. Dia of the sheave
3. Material of the sheave
4. No. of grooves provided.

II. GEARING

1. Type
2. Make and Type designation if any.
3. Reduction ratio
4. Material of the geared wheel
5. Material of the worm shaft
6. Type of lubricant
7. Quantity of Lubricant Ltrs.
8. Over all mechanical efficiency
9. Power ratio

SR. No.	DESCRIPTION
------------	-------------

III. BRAKE

1. Type
2. Maker's type designation if any.
3. Braking forces
4. Service duty No. of applications/hr.
5. Material of lining.

IV. LIFT MOTOR

1. Type
2. Maker's type designation if any
3. Rating KW
4. Service duty No. of application/hr.
5. Rated speed of operation r.p.m.
6. Rated voltage
7. Class of insulation

(C) ROPES & ROPING SYSTEM

1. Type of roping system
2. No. of lifting ropes
3. Dia. of lifting ropes
4. Breaking load of each rope.
5. Factor of safety of the complete rope system.
6. Method of rope fastening.

(D) GUIDES FOR CAR & COUNTER WEIGHT

1. Section
2. Weight per metres run
3. Material and strength
4. Finish of working design
5. Distance between support brackets

SR. No.	DESCRIPTION
------------	-------------

(E) SAFETY FEATURES

1. Type of mechanical Safety Governor.
2. Governor tripping speed M/Sec.
3. Safety gear stopping distance m.
4. Normal terminal stoppings.
5. Final terminal stopping switches.
6. Car bottom run by m.
7. Car bottom clearance m.
8. Car top clearance m.
9. Counter weight bottom run up m.
10. Counter weight top clearance m.
11. Type of Car buffers
12. Strength of Car buffers
13. Type of counter weight buffers.
14. Strength of counter weight buffers.

(F) CONTROLLING SYSTEM AND CONTROLLER

1. Type of control system.
2. Manufacture's type and designation
3. Operating voltage of the relays & coils
4. Any other particulars which the tenderer wish to state.

Any other improved specifications

SCHEDULE OF DELIVERY AND ERECTION

Fill up this programme of work and submit alongwith tender.

SR. No.	DESCRIPTION OF ITEMS	No. OF WEEKS FROM THE DATE OF ISSUE OF WORK-ORDER
1.	<u>SUPPLY OF PRELIMINARY DRAWINGS</u>	
	(a) General Arrangement drawings	_____ Weeks
	(b) Electrical Wiring drawings	_____ Weeks
	(c) Foundation and other details	_____ Weeks
	(d) Any other drawings as per Specification	_____ Weeks
2.	<u>INSTALLATION PROGRAMME</u>	
	(a) Delivering the material to Site	_____ Weeks
	(b) Total time for erection and commissioning of lift	_____ Weeks
	(c) Car Assembly	_____ Weeks
	(d) Installation of Lift / Machine etc.	_____ Weeks
	(e) All Wiring Work	_____ Weeks
	(f) Testing and Commissioning	_____ Weeks

SIGNATURE OF TENDERER

CONTRACTOR

No. of correction

REGISTRAR

SCHEDULE OF MANUFACTURER ADDRESS

Sr. No.	DESCRIPTION OF ITEM	ADDRESS OF THE MANUFACTURER
1.	LIFT CAR	
2.	LIFT MACHINE	
3.	CONTROLLER	
4.	WIRE ROPES	
5.	CAR & COUNTER WEIGHTGUIDES	
6.	AND OF ALL OTHER ITEMS	

SIGNATURE OF TENDERER

CONTRACTOR

No. of correction

REGISTRAR

Supply, installation, testing and commissioning of MRL (Machine Room less) One No. 10 (ten) & five Nos. 15 (fifteen) passenger lifts including minor civil work at Administrative Building and Examination Bhavan at Punyashlok Ahilyadevi Holkar Solapur University, Solapur.

LIST OF TENDER DRAWING

Drawing No. SOL-UNI-ADM-A.326 : Plans, Sections
Elevation and details of
15 passenger lift and 10 passenger lift

CONTRACTOR

No. of correction

REGISTRAR

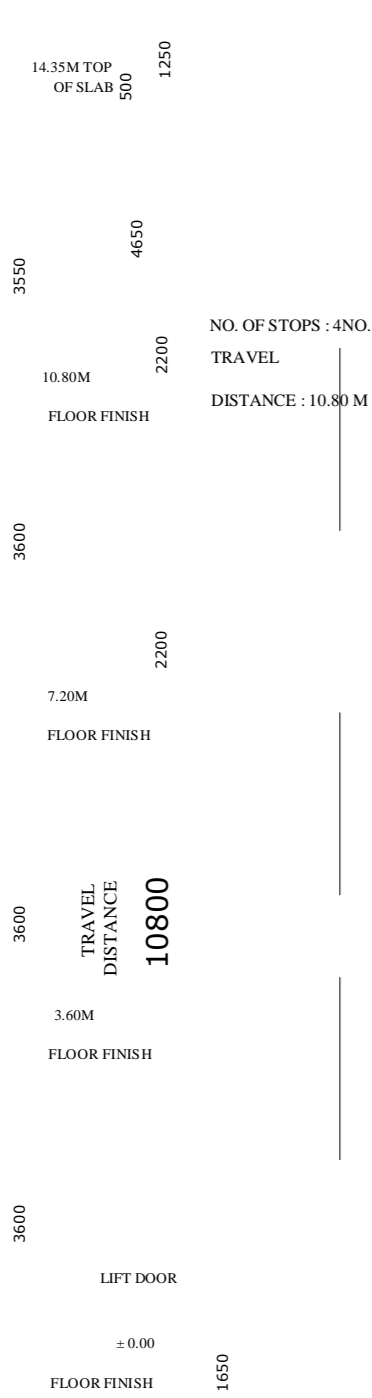

SECTION A-A

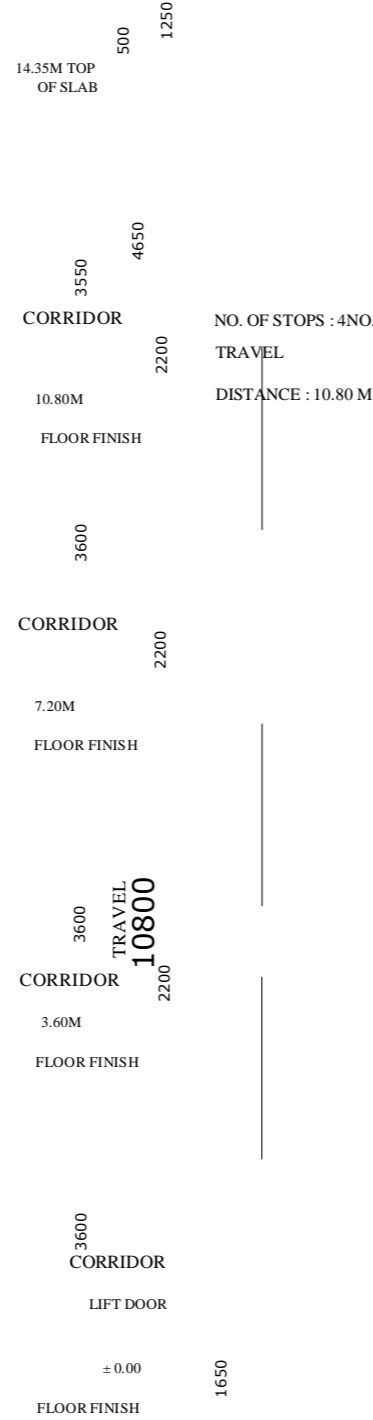

SECTION B-B

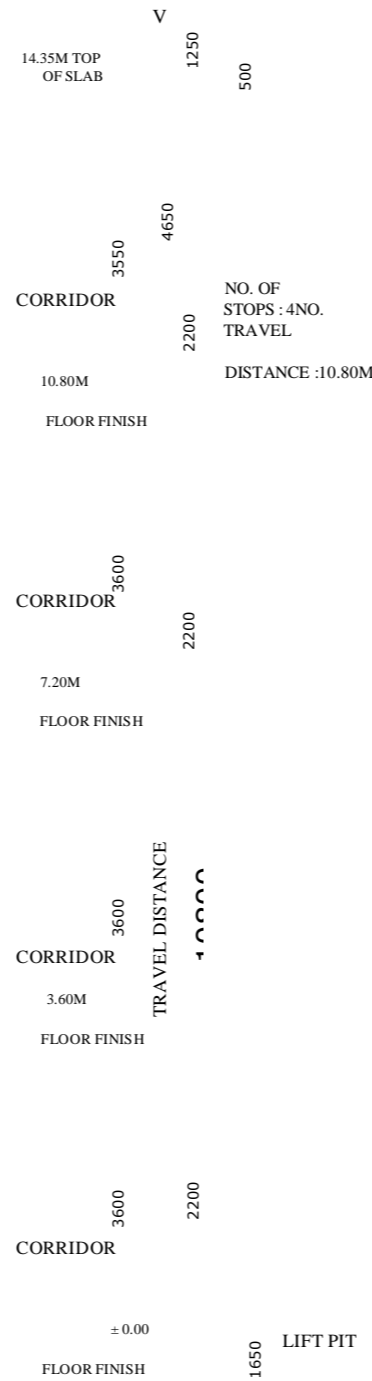

SECTION C-C

36

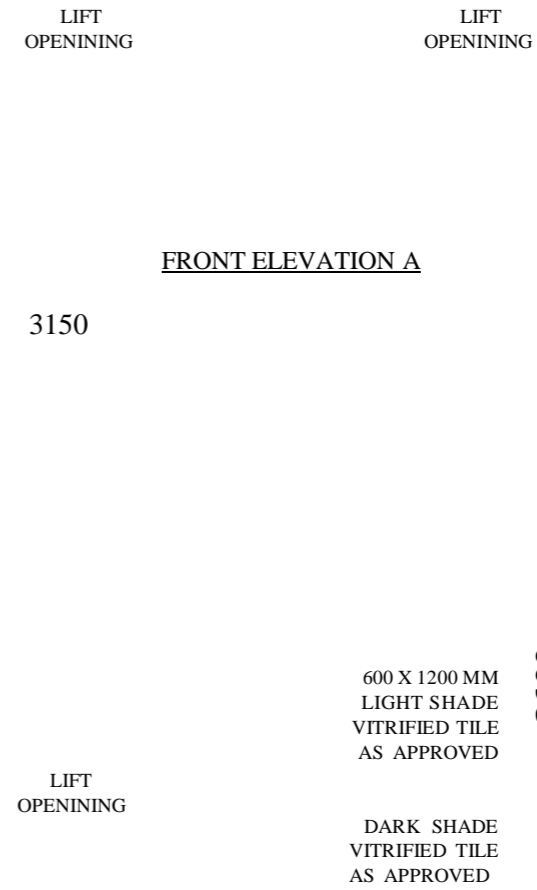

FRONT ELEVATION B

FRONT ELEVATION C

SCALE- 1:50

NO. OF LIFTS :

15 PASSENGER : 5 NOS.

10 PASSENGER : 1 NOS.

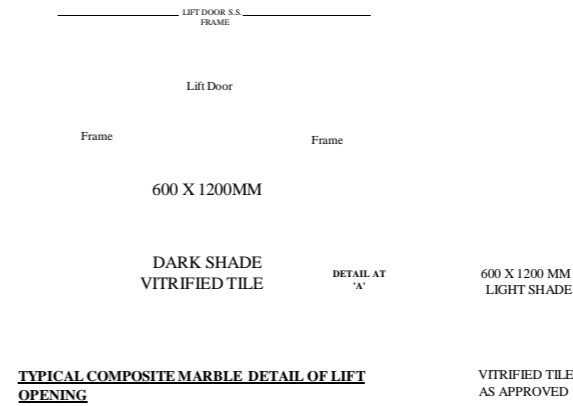

TYPICAL COMPOSITE MARBLE DETAIL OF LIFT OPENING

VITRIFIED TILE AS APPROVED

REVISION INITIAL DATE NO.

JOB TITLE

ADMINISTRATIVE BUILDING COMPLEX SOLAPUR UNIVERSITY

DRAWING TITLE

S1 R

H1 I I

C C

A 2500

A

31

2500

2000

C

2370

1605

LIFT 2575

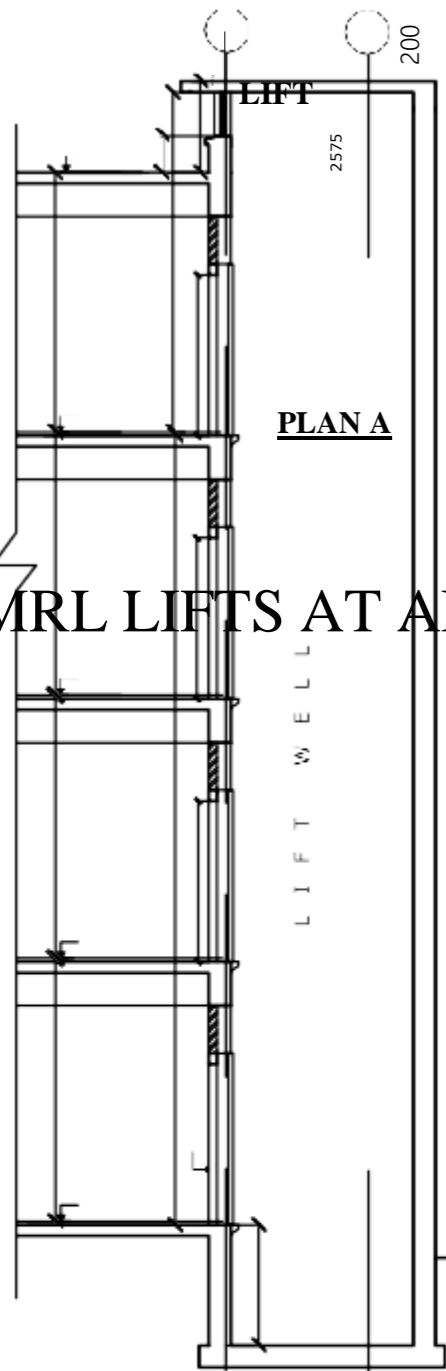

PLAN A



PLAN B

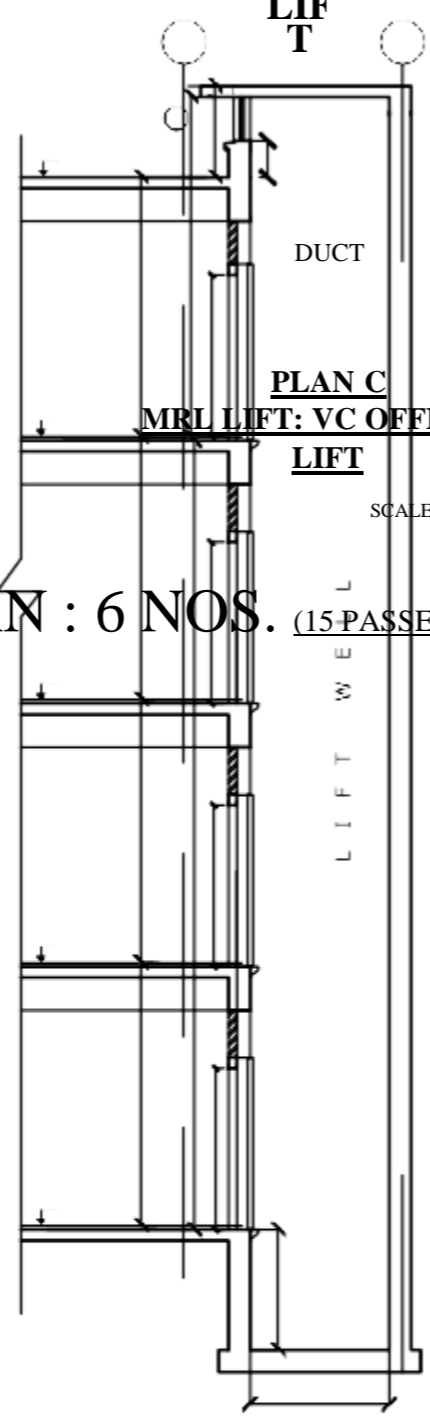

PLAN C
MRL LIFT: VC OFFICE :1
LIFT

SCALE- 1:100

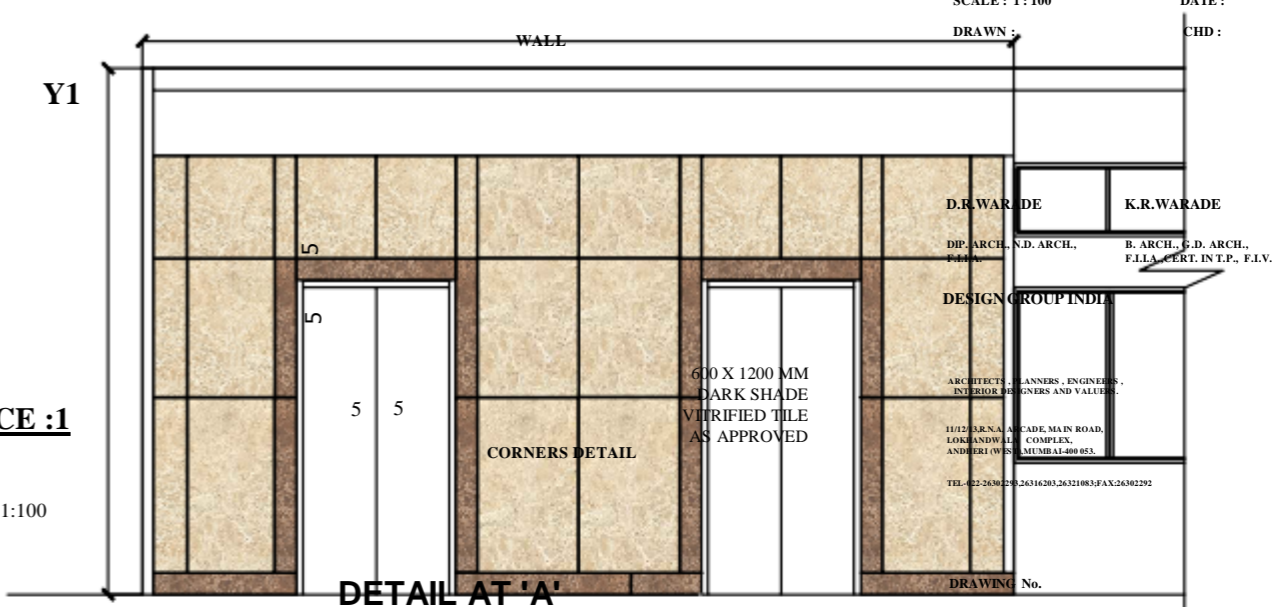

DETAIL AT 'A'

SOL.UNI-ADM - A-326

MRL LIFTS AT ADMIN. AND EXAM BHAVAN : 6 NOS. (15-PASSENGERS : 5 NOS + 10 PASSENGERS : 1NOS)

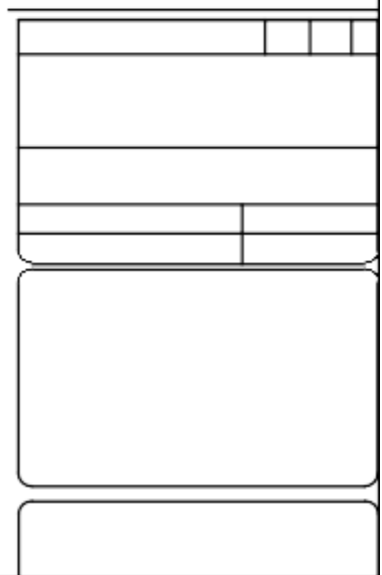
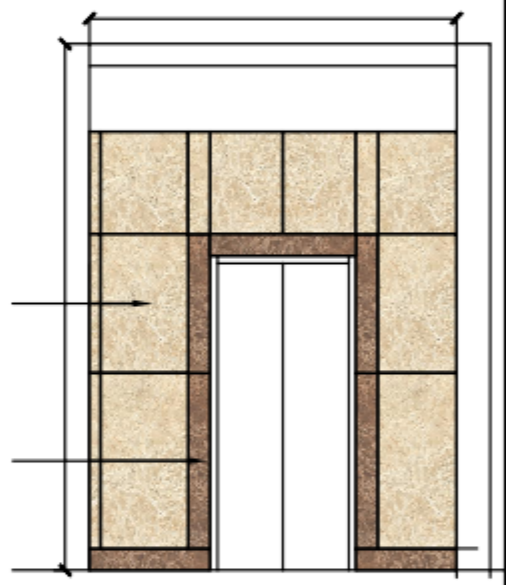
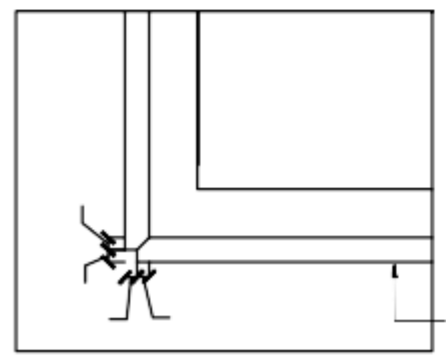
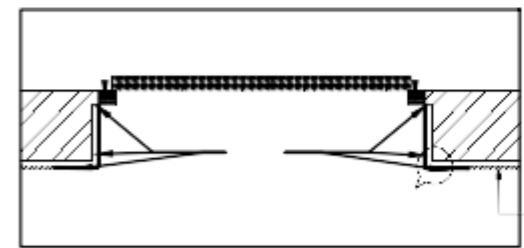
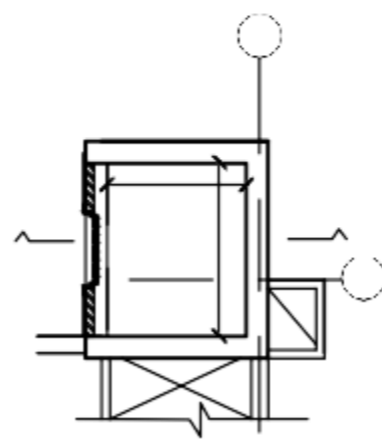
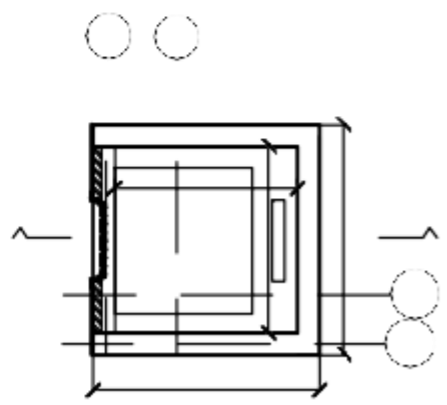
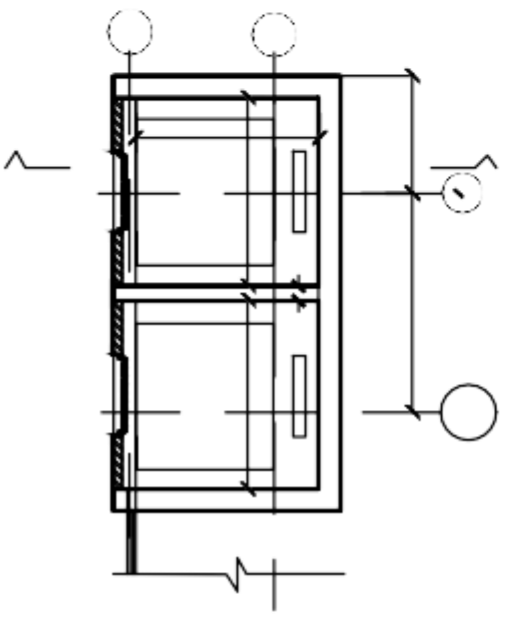

LIST OF PREFERRED BRAND / MAKES OF EQUIPMENT REQUIRED UNDER THIS TENDER

1	Lifts	:	Lifts shall be only of most reputed leading manufacturers having over above Rs. Thirty Crores of supply, installation, testing and lift commissioning of MRL lift
	NOTE : The quotations shall be submitted only by reputed manufacturers.		The lift manufacturer shall submit details of make of their all parts, equipment they are using in their lifts.
2	Electric cable	:	Finolex, Polycab.
3	PVC casing / capping	:	Precision
4	MCCB (DP, TP / FP)	:	L & T, Siemens / Legrand
5	MCCB : Distribution board	:	Legrand, Siemens
6	Main steel ropes	:	Usha Martin
7	Flooring of lift	:	‘ Z ‘ black granite without any spot.
8	Structural members for RINL fabrication work	:	TATA, SAIL,
9	Cat 6 cable for camera	:	Polycab, Molex
10	Modular type switch	:	Anchorwood
11	Bulk-head with LED bulb	:	Make as approved by the University Engineer / Architect
12	Any other materials, equipments :		Make as approved by the University Engineer / Architect.

I hereby read and understand the make of the above materials / equipment and shall use the materials / equipment only of the above make companies / manufacturers.

No extra payment whatsoever will be made for using the above materials. I / We shall not use any duplicate fitting, materials etc. If found, I / We shall be liable for any action imposed by the University Engineer / PMC / Architect and such materials should be removed immediately and replaced with approved make material.

In case any of the above materials / equipments are not available of the given make, then we shall use the materials / equipments as directed by the University Engineer / PMC / Architect on reducing the rate and obtaining the letter from the Specified manufacture that such materials is not available and not being manufacture.

Where-ever equivalent product / accessories is written it has to be approved from the University Engineer / PMC / Architect.

ON Rs. 500/- stamp-paper

NOTE : Seperate Guarantee for Annual Comprehensive maintenance contract for 5 Nos. – 15 passenger lifts and one number – 10 passenger lift shall be provided.

GUARANTEE TO BE EXECUTED BY THE CONTRACTORS FOR COMPREHENSIVE GUARANTEE

Name of Work : **Supply, installation, testing and commissioning of MRL (Machine Room less) five Nos. 15 (fifteen) passenger and One No. 10 (ten) passenger lifts including minor civil work at Administrative Building and Examination Bhavan at Punyashlok Ahilyadevi Holkar Solapur University, Solapur.**

Work Order dated _____.

This agreement made this day of _____ two thousand Twenty Two and _____ between _____ (hereinafter called the Guarantor of the one part) and the Punyashlok Ahilyadevi Holkar Solapur University, Solapur hereinafter called the Owner of the other part)

WHEREAS THIS agreement is supplementary to the work order herein after called Comprehensive guarantee dated _____ and made between the GUARANTOR OF THE ONE part and OWNER of the other part, whereby the Contractor, inter alia, undertook to render the guarantee as given in work-order recited completed in perfect working condition.

AND WHEREAS THE GUARANTOR agreed to give a comprehensive guarantee to the effect that the said lifts and equipments etc. will remain in perfect working order for one year + two months + five years AMC period as per work-order.

NOW THE GUARANTOR hereby warrants that the Lifts, equipments, etc. given by him will render the perfect service for FIVE years to be reckoned from the date of expiry of defect liability period i.e. total one year & two months + 5 years after the testing, commissioning & handing over prescribed in the contract and from the date of final bill whichever is later.

Provided that the guarantor will not be responsible for failure caused by earthquake or misuse / alteration of system and for such purpose :

- (a) Misuse shall mean operation which will damage installation, like chopping of fire wood and things of the same nature which might cause damage.
- (b) Alteration shall mean installation of an additional equipments / lifts or a part or equipments adjoining to existing equipments whereby system is removed in parts or tempered.
- (c) The decision of the University Engineer with regard to cause of defect / failure shall be final.

During this period of warrantee the guarantor shall make good all defects and in case of any defect being found render the system to the satisfaction of the Owner at his cost and shall commence the work for such rectification within two days from the date of issue of the notice from the Owner calling upon him to rectify the defects failing which the work shall be got done by the Owner by some other contractor at the GUARANTOR'S cost and risk. The decision of the University Engineer / PMC / Architect as to the cost payable by the Guarantor shall be final and binding.

That if the Guarantor fails to execute the rectification or commits breach there under then the Guarantor will indemnify the Principal and his successors against all loss, damage, cost expense or otherwise which may be incurred by him by reason of any default on the part of the Guarantor in performance and observance of this supplemented agreement. As to the amount of loss and / or damage and cost incurred by the Owner the decision of University Engineer / Architect / PMC will be final and binding on the parties.

The guarantor shall give the bank guarantee for 10% of the Equipment value valid during the warrantee period of two years.

CONTRACTOR

No. of correction

REGISTRAR

- 2 -

IN WITNESS WHEREOF these presents have been executed by the Obligator (Guarantor)

and by PUNYASHLOK AHILYADEVJI HOLKAR SOLAPUR UNIVERSITY, SOLAPUR – 413 255.
for and on behalf of the Owner on the day, month and year first above written.

SIGNED SEALED AND DELIVERED BY (Obligator / Guarantor) in the presence of :1.

2.

SIGNED FOR AND ON THE OWNER BY in the presence of :1.

2.

CONTRACTOR

No. of correction

REGISTRAR

BASIC CHECK LIST BEFORE HANDING OVER THE LIFT**10 PASSENGER LIFT 680 Kg.****15 PASSENGER LIFTS 1020 Kg.**

This shall be in addition to compliance of conditions stated in contract documents

Sr. No.	PARTICULARS	REMARKS
1.	Proper levels at all floors	
2.	Auto Rescue device	
3.	Automatic evacuation to nearest floor	
4.	Intercom system	
5.	Fireman	
6.	Watchmen	
7.	Emergency light and alarm	
8.	Overloaded indicator	
9.	Attendant operation : two sets	
10.	Operating manuals Safety manuals : two sets	
11.	Inspection reports : certified two sets	
12.	Commissioning reports : two sets	
13.	All test reports : two sets	
14.	Light cover of lift : fill with dust	
15.	Wall panel of the lift-not in line and coming out	
16.	Flooring	
17.	Closing of doors without creating sound : as in one lift doors create sound	
18.	Polishing of cars and doors as it is full with stains, removing of plastic cover	
19.	Checking with checklist (prescribed)	
20.	Door keys : 3 Nos. Emergency keys	
21.	Control cabinet keys : 3 Nos.	
22.	Fan	
23.	Lights	

CONTRACTOR

No. of correction

REGISTRAR

BASIC COMPLYING SPECIFICATION

This shall be in addition to compliance of conditions stated in contract documents.

Sr. No.	FEATURES	SPECIFICATION
1.	Door Drive : Frequency convertor : Fully controlled obstacle Detection torque limitation	
2.	Car operating panel	
3.	Multi-beam full height infra-red detector	
4.	Touch sensitive glass	
5.	Handrail in S.S. 316	
6.	Duplex system	
7.	Car : SS hairline	
8.	Mirror	
9.	PWD license original copy	
10.	Laminated PWD License display in the car	
11.	Will it be possible to operate lift from ground to 4 th floor temporarily	
12.	Touch panel	
13.	Cleaning of car & door	

CONTRACTOR

No. of correction

REGISTRAR

DRAFT - BANK GUARANTEE

Note : The separate bank guarantee shall be submitted for 5 Nos. 15 passenger lifts and one number 10 passenger lift.

We, _____, do hereby undertake to pay the amount due and payable under this guarantee without any demur, merely on receipt of a demand in writing on or before _____ from the OWNER known as Punyashlok Ahilyadevi Holkar Solapur University, Solapur stating that the amount claimed is due by way of failure on the part of the CONTRACTOR known as _____ for loss or damage caused to or would be caused to or suffered by the OWNER known as Punyashlok Ahilyadevi Holkar Solapur University, Solapur for reason of any breach by the said Contract Agreement of any of the terms or conditions contained in the said contract Agreement. Any such demand made on the Bank shall be conclusive as regards the amount due and payable by the Bank under this guarantee without any query, however, our liability under this guarantee shall be restricted to the amount not exceeding Rs. _____ (Rupees _____)

1 We bank name, further agree that the Guarantee herein contained shall remain in full force and effect during the period that will be taken for the Performance of the said works as per Contract Agreement that it shall continue to be enforceable till all the dues of the Owner known as Punyashlok Ahilyadevi Holkar Solapur University, Solapur under or by virtue of the said Works have been fully performed and its claim satisfied or discharged and unless the OWNER known as Punyashlok Ahilyadevi Holkar Solapur University, Solapur certifies that the terms and conditions of the said Works or Contract Agreement have been fully and properly carried out by the CONTRACTOR known as _____ and accordingly discharges this Guarantee on _____

We shall be discharged from all liabilities under this guarantee thereafter.

2 We, bank name, further agree that the OWNER known as _____ shall have the fullest liberty without our consent and without affecting in any manner our obligations hereunder to carry any of the terms and conditions of the said works or contract agreement or to extend the time of performance by the CONTRACTOR known as _____ from time to time or to postpone for any time or from time to time any of the powers exercisable by the OWNER known as Punyashlok Ahilyadevi Holkar Solapur University, Solapur against the CONTRACTOR known as _____ and to forbear or enforce any of the terms and conditions relating to the said contract agreement and we shall not be relieved from our liability by reason of such variation or extension being granted to the said CONTRACTOR known as _____ or for any forbearance, act

or omission by the OWNER known as Punyashlok Ahiyadevi Holkar Solapur University, Solapur to the CONTRACTOR known as

_____ or by any such matter of thing / provision have effect of so relieving us.

- 3 Notwithstanding anything contained herein above, our liability under this Guarantee is restricted to a sum of Rs. _____ (Rupees _____ only), and the Guarantee is valid upto _____. We shall be released and discharged from all liabilities hereunder unless a written claim for payment under this Guarantee is lodged on or before _____, irrespective of whether or not the original guarantee is returned to us.

Please not that you may, if you so required, independently seek confirmation with _____, Bank address that this guarantee has been duly and validly issued.

Notwithstanding anything to the contrary contained herein, the liability of Bank Name under this guarantee is restricted to a maximum total amount of Rs. _____ (Rupees _____ only). Our guarantee shall remain in force until _____.

Our liability pursuant to this guarantee is conditional upon the receipt of a valid and duly executed written claim, in original, by Bank name and address, delivered by hand, courier or registered post, prior to close of banking business hours on _____, failing which all rights under this guarantee shall be foreited and bank name, shall stand absolutely and unequivocally discharged of all of its obligations hereunder. This Guarantee shall be governed by and construed in accordance with the laws of India and competent courts in the city of Solapur shall have exclusive jurisdiction.

Kindly return the original of this guarantee to bank name and address, upon the earlier of (a) its discharge by payment of claims aggregating to Rs. _____

(Rupees _____ only) (b) Fulfillment of the purpose for which this guarantee was issued; or (c) _____

All claims under this guarantee will be made payable at bank name and address.

SITE VISIT / SURVEY
REPORT

- 1 Tender ID :-
- 2 Bidder Details (Name of Agency / Bidder) :-
- 3 Bidder Representative – Name & Designation :-
- 4 Details of site / Name of work :- Supply, installation, testing and commissioning MRL (Machine Room less) five Nos. (fifteen) passenger and One No. 10 (ten) passenger lifts including minor civil work at Administrative building and Examination Bhavan at Punyashlok Ahilyadevi Holkar Solapur University, Solapur.
- 5 Date of site visit :-

In compliance to above referred tender enquiry and special terms & condition regarding site visit, the bidder must visit above site before the tender submission date and understand the requirements before participating the bid.

Accordingly, I / we have visited and examined the building and site with all physical features, contours, characteristic, the approach and all other requisite information relating thereto as affecting the tender invited by the University.

- i) I / we have understood the site conditions, I / we will be binded to complete the work of installation, testing and commissioning the work within the time period mentioned in the tender.
- ii) I / We have understood the details scope of the work exclusively defined in the technical specification.

Bidder's authorized representative

Name _____

Sign _____

Date _____

UNIVERSITY ENGINEER
Punyashlok Ahilyadevi Holkar

Solapur University,

Signature

OR

Project Engineer
Design Group (India),

Architects and Project Management
Consultant

Signature

(Note : If the site visit / Survey report is not submitted, then the bid will not be opened.)



The Registrar
Punyashlok Ahilyadevi Holkar
Solapur University, Solapur – 413 255

For the work of : Supply, installation, testing and commissioning of MRL (Machine Room less) five Nos. 15 (fifteen) passenger and One No. 10 (ten) passenger lifts including minor civil work at Administrative Building and Examination Bhavan at Punyashlok Ahilyadevi Holkar Solapur University, Solapur.

ENVELOPE No. 2

FINANCIAL BIDS

SEPERATELY OF

15 (FIFTEEN PASSENGER) – 5 Nos. MRL LIFTS

and

10 (TEN PASSENGER) – 1 No. MRL LIFT

VOLUME – II / LETTER OF OFFER (for 10 passenger lift)

(Draft Letter)

The contractor should submit his offer on his letter head only as per this DraftLetter.

THE REGISTRAR

PUNYASHLOK AHILYADEVI HOLKAR SOLAPUR UNIVERSITY
KEGAON

SOLAPUR – 431 606.

DEAR SIR,

**Supply, installation, testing and commissioning of MRL (Machine Room less)
One No. 10 (ten) passenger lifts including minor civil work at Administrative Building
and Examination Bhavan at Punvashlok Ahilyadevi Holkar Solapur University, Solapur.**

We have gone through the tender conditions and specifications stipulated in Volume I for the supply, installation, testing and commissioning of MRL (Machine Room less) One No. 10 (ten) passenger lifts including minor civil work at Administrative Building and Examination Bhavan at Punyashlok Ahilyadevi Holkar Solapur University, Solapur and we confirm to have accepted all terms and conditions of volume I.

The total cost of this work shall be Rs. _____ (Rupees _____)

We also accept the following terms and conditions of payment.

(a) 30% value as advance on submission

of irrevocable bank guarantee from nationalised bank and bill and only on issue of work-order and its confirmation and acceptance from you

(b) On supply of material, equipment etc.

75% of cost of material as secured advance as per contract conditions pro-rate to the material supplied at site

on recommendation of the University Engineer(the extent of material of equipment component is considered 80% of

the total contract price) i.e. total payment

i.e. 75% of 80% =

60%

30% of advance given as advance on submission of bank guarantee will be recovered in this stage of payment i.e. the payment at this stage shall

be 60% - 30% = 30%

- (c) 25% of contract value on successful completion of erection, testing & commissioning
of lift & obtaining PWD licence for safe operation. 25%
i.e. cumulative payment at this stage shall be 85%.60% + 25% = 85%

CONTRACTOR

No. of correction

REGISTRAR

- (d) 10% of the contract value on handing over of the lift against submission of performance Bank

guarantee from nationalised bank.

10%

$85\% + 10\% = 95\%$

- (e). Total security deposit is 5% of total executed cost shall be retained till one year and two months of defect liability period from testing, commissioning, handing over and obtaining PWD license and from date of final bill whichever is later.

$95\% + 5\% = 100\%$

(This price bid is to be submitted separately in sealed Envelope No. 2)

Contractors Signature and Seal

CONTRACTOR

No. of correction

REGISTRAR

(DRAFT LETTER)
(for 10 passenger lift)

The contractor should submit this Annual Comprehensive Maintenance and Service Contract on his letter head with cost.

THE REGISTRAR

PUNYASHOLK AHILYADEVI HOLKAR SOLAPUR UNIVERSITY
KEGAON,

SOLAPUR – 413 255.

Dear Sir,

Supply, installation, testing and commissioning of MRL (Machine Roomless) One No. 10 (ten) passenger lifts including minor civil work at Administrative Building and Examination Bhavan at Punyashlok Ahilyadevi Holkar Solapur University, Solapur.

We also further quote for next five years after the defects liability period of one year and two months is over for Comprehensive Maintenance and Service. Such payments shall be made quarterly or in mid of quarter.

1. The contractor shall provide free comprehensive service and maintenance guarantee for a period of one year and two months as defect liability period from the date of handing over the lifts as per contract conditions.
2. The contractor shall quote separately for yearly comprehensive maintenance contract, against the quarterly instalment.

Note : The charges shall be exclusive of GST and as considering all the conditions of contract & AMC as stated in volume I of conditions of contract.

Sr. No.	PERIOD	IN FIGURE	IN WORDS
1.	First one year and two months defect liability period	Free	Free
2.	For second year	Rs.	
3.	For third year	Rs.	
4.	For fourth year	Rs.	
5.	For fifth year	Rs.	
6.	For sixth year	Rs.	

Note : This price bid shall be placed in separate sealed envelope.

CONTRACTOR

No. of correction

REGISTRAR

3. The maintenance shall consist of regular monthly examination and any necessary adjustment and lubrication of the equipment by competent contractor's technical staff including replacement of damaged parts and as per conditions of annual comprehensive maintenance contract.
4. Upon requests from the Punyashlok Ahilyadevi Holkar Solapur University as and when required for rectifying defective functioning, the contractor shall send his technician within maximum period of 1 hour and put the lift in order without delay.

Cost per annum Rs. _____

Rupees _____) \
to be paid quarterly.

Contractors Signature and Seal.

CONTRACTOR

No. of correction

REGISTRAR

VOLUME – II/ LETTER OF OFFER (for 15 passenger lift)

(Draft Letter)

The contractor should submit his offer on his letter head only as per this DraftLetter.

PUNYASHLOK AHILYADEVIL HOLKAR SOLAPUR UNIVERSITY
KEGAON

SOLAPUR – 431 606.

DEAR SIR,

**Supply, installation, testing and commissioning of MRL (Machine Room less)
five Nos. 15 (fifteen) passenger lifts including minor civil work at administrative building
and Examination Bhavan at Punvashlok Ahilyadevi Holkar Solapur University, Solapur.**

We have gone through the tender conditions and specifications stipulated in Volume I for the supply, installation, testing and commissioning of MRL (Machine Room less) five Nos. 15 (fifteen) passenger lifts including minor civil work at administrative building and Examination Bhavan at Punyashlok Ahilyadevi Holkar Solapur University, Solapur and we confirm to have accepted all terms and conditions of volume I.

The total cost of this work shall be Rs. _____ (Rupees _____)
_____)

We also accept the following terms and conditions of payment.

(a) 30% value as advance on submission

of irrevocable bank guarantee from nationalised bank and bill and only on issue of work-order and its confirmation and acceptance from you

(b) On supply of material, equipment etc.

75% of cost of material as secured advance as per contract conditions pro-rate to the material supplied at site

on recommendation of the University Engineer(the extent of material of equipment component is considered 80% of

the total contract price) i.e. total payment

i.e. 75% of 80% = 60%

30% of advance given as advance on submission of bank guarantee will be recovered in this stage of payment i.e. the payment at this stage shall

be 60% - 30% = 30%

- (c) 25% of contract value on successful completion of erection, testing & commissioning of lift & obtaining PWD licence for safe operation. 25%
i.e. cumulative payment at this stage shall be 85%.60% + 25% = 85%

CONTRACTOR

No. of correction

REGISTRAR

- (d) 10% of the contract value on handing over of the lift against submission of performance Bank

guarantee from nationalised bank. 10%
 $85\% + 10\% = 95\%$

- (e). Total security deposit is 5% of total executed cost shall be retained till two years of defect liability period from testing, commissioning, handing over and obtaining PWD license and from date of final bill whichever is later.

$95\% + 5\% = 100\%$

(This price bid is to be submitted separately in sealed Envelope No. 2)

Contractors Signature and Seal

CONTRACTOR

No. of correction

REGISTRAR

**(DRAFT LETTER)
(for 15 passenger lift)**

The contractor should submit this Annual Comprehensive Maintenance and Service Contract on his letter head with cost shall be submitted in sealed envelope.

THE REGISTRAR

PUNYASHLOK AHILYADEVJI HOLKAR SOLAPUR UNIVERSITY
KEGAON,

SOLAPUR – 413 255.

Dear Sir,

Supply, installation, testing and commissioning of MRL (Machine Room less) five Nos. 15 (fifteen) passenger Lifts including minor civil work at administrative building and Examination Bhavan at Punyashlok Ahilyadevi Holkar Solapur University, Solapur.

We also further quote for next five years after the defects liability period of one year and two months is over for Comprehensive Maintenance and Service. Such payments shall be made quarterly or in mid of quarter.

1. The contractor shall provide free comprehensive service and maintenance guarantee for a period of one year and two months as defect liability period from the date of handing over the lifts as per contract conditions.
2. The contractor shall quote separately for yearly comprehensive maintenance contract, against the quarterly instalment.

Note : The charges shall be exclusive of GST and as considering all the conditions of Contract & AMC as stated in volume I of conditions of contract.

Sr. No.	PERIOD	IN FIGURE	IN WORDS
1.	First one year and two months defect liability Period	Free	Free
2.	For second year		
3.	For third year		
4.	For fourth year		
5.	For fifth year		
6.	For sixth year		

Note : This price bid shall be placed in separate sealed envelope.

CONTRACTOR

No. of correction

REGISTRAR

3. The maintenance shall consist of regular monthly examination and any necessary adjustment and lubrication of the equipment by competent contractor's technical staff including replacement of damaged parts and as per conditions of annual comprehensive maintenance contract.
4. Upon requests from the Punyashlok Ahilyadevi Holkar Solapur University as and when required for rectifying defective functioning, the contractor shall send his technician within maximum period of 1 hour and put the lift in order without delay.

Cost per annum Rs. _____

Rupees _____) \

To be paid quarterly.

Contractors Signature and Seal.

CONTRACTOR

No. of correction

REGISTRAR